Sup/IRBuck™

USER GUIDE FOR IR38060 EVALUATION BOARD

DESCRIPTION

The IR38060 is a synchronous buck converter with a PMBus interface, providing a compact, high performance and flexible solution in a small 5mmx6mm PQFN package.

Key features offered by the IR38060 include I2C/PMBus configurability of output voltage, soft-start, input UVLO, input overvoltage protection, output overvoltage protection, output overcurrent protection, Power Good, thermal protection and switching frequency. Additionally, the IR38060 also features enhanced line/ load regulation with feed forward, external frequency synchronization with smooth clocking, internal LDO, true differential remote sensing and pre-bias start-up.

A temperature and bias compensated output over-current protection function is implemented by sensing the voltage developed across the on-resistance of the synchronous rectifier MOSFET for optimum cost and performance.

This user guide contains the schematic and bill of materials for the IR38060 evaluation board. The guide describes operation and use of the evaluation board itself. Detailed application information for IR38060 is available in the IR38060 data sheet.

BOARD FEATURES

- $P_{Vin} = +12V (+ 13.2V \text{ Max})$, **No Vcc required.**
- $V_{out} = +1.2V @ 0-6A$
- $F_s = 600kHz$
- $L = 0.82\mu H$
- $C_{in} = 3 \times 22\mu F$ (ceramic 1206) + $1 \times 330\mu F$ (electrolytic, optional)
- $C_{out} = 7 \times 22\mu F$ (ceramic 0805)

CONNECTIONS and OPERATING INSTRUCTIONS

A well regulated +12V input supply should be connected to PVin+ and PVin-. A maximum of 6A load should be connected to VOUT+ and VOUT-. The inputs and output connections of the board are listed in Table I.

IR38060 needs only one input supply and internal LDO generates Vcc from PVin. Another internal LDO generates the 1.8V needed by the internal digital circuits. If operation with external Vcc is required, then R25 should be removed and external Vcc can be applied between Vcc+ and Vcc- pins. Vin pin and Vcc pins should be shorted together for external Vcc operation by installing R24. **For normal, non-tracking operation, R27 should not be populated and a 100 kOhm resistor should be connected from the Track_En pin to P1V8.**

The board is configured for remote sensing. If local sense is desired, R8 should be uninstalled and R16 should be installed instead.

I2C/PMBus communication is established through the 4 pin header which allows connection to the SCL/SDA/SALERT and GND lines from the host/dongle. For proper operation in digital communications mode, R35 must always be populated.

External Enable signal can be applied to the board via exposed Enable pad and *R18 should be removed for this purpose.*

Table I. Connections

Connection	Signal Name
PVin+	PVin (+12V)
PVin-	Ground of Pvin
Vout+	Vout(+1.2V)
Vout-	Ground for Vout
Vcc+	Vcc Pin
Vcc-	Ground for Vcc input
Enable	Enable
PGood	Power Good Signal

LAYOUT

The PCB is a 4-layer board. All of layers are 2 Oz. copper. The IR38060 and most of the passive components are mounted on the top side of the board. Power supply decoupling capacitors and feedback components are located close to IR38060. The feedback resistors are connected to the output of the remote sense amplifier of the IR38060 and are located close to the IR38060. To improve efficiency, the circuit board is designed to minimize the length of the on-board power ground current path. Separate power ground and analog ground are used and may be connected together using a 0 ohm resistor.

CONNECTION DIAGRAM

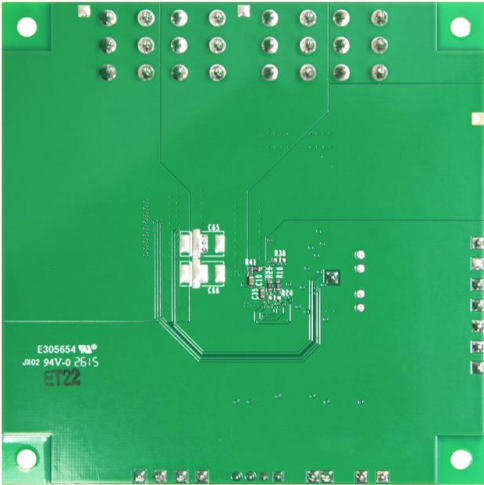
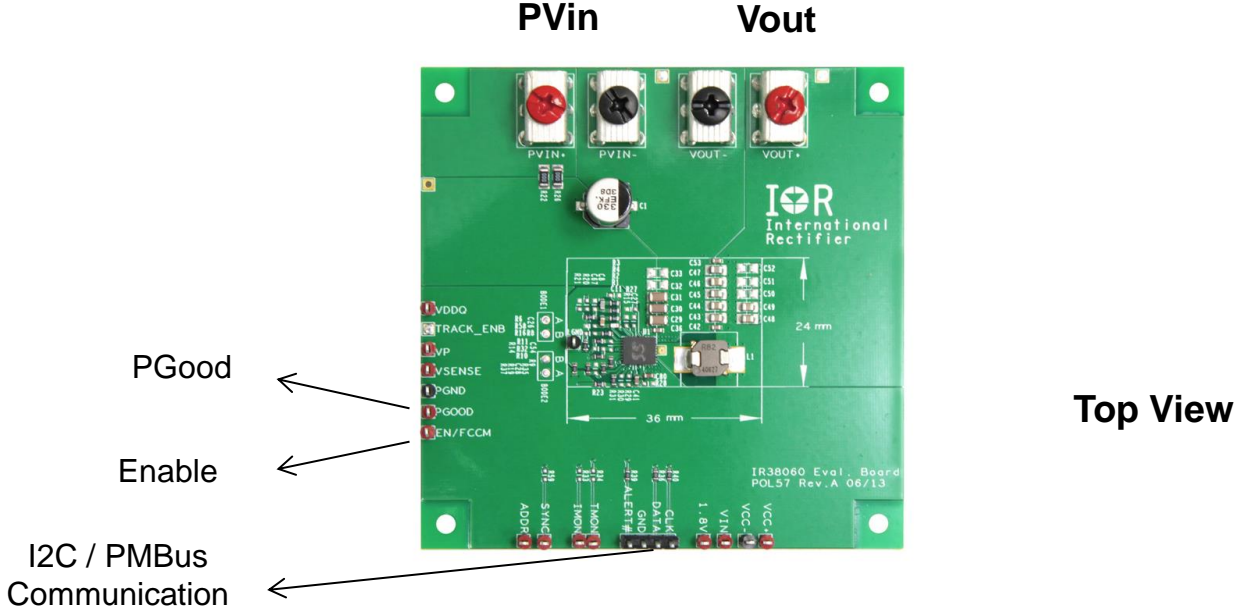

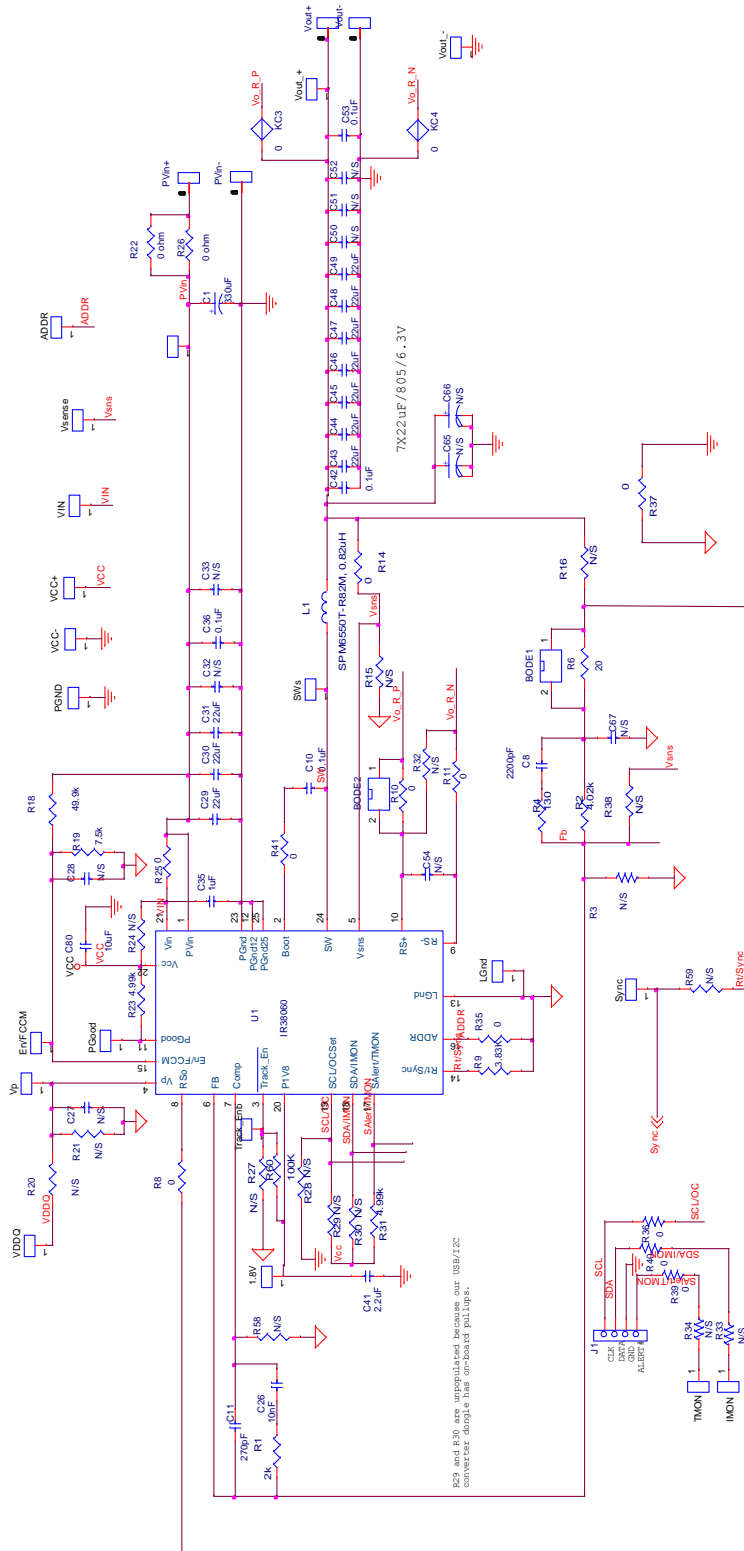

Fig. 1: Schematic of the IR38060 evaluation board

Bill of Materials

Item Number	Quantity	Part Reference	Value	Description	Manufacturer	Part Number
1	1	C1	330uF	SMD Electrolytic, F size, 25V, 20%	Panasonic	EEE-FK1E331P
2	1	C8	2200pF	2200pF, 0603, 50V, NPO	TDK	C1608C0G1H222J
3	1	C11	270pF	50V, 0603, NP0, 5%	Murata	GRM1885C1H271JA01D
4	1	C26	10nF	0603, 50V, X7R, 10%	Murata	GRM188R71H103KA01D
5	3	C29 C30 C31	22uF	22uF, 1206, 25V, X5R, 20%	TDK	C3216X5R1E226M160AB
6	4	C10 C36 C42 C53	0.1uF	0603, 50V, X7R, 10%	Panasonic	ECJ-1VB1H104K
7	1	C35	1uF	0603, X5R, 25V, 20%	TDK	C1608X5R1E105M
8	7	C43 C44 C45 C46 C47 C48 C49	22uF	0805, 6.3V, X5R, 20%	Murata	GRM21BR60J226ME39
9	19	LGND 1.8V ADDR EN/FCCM IMON PGND PGOOD SW SYNC TMON VCC+ VCC- VDDQ VIN VIN_+ VOUT_+ VOUT_- VP VSENSE	0.075" SQ_SMT_ TestPoint			TP-200-125
10	1	J1	Header-4P			
11	1	C41	2.2uF	0603, 10V, X5R, 20%	TDK	C1608X5R1A225M080AC
12	1	R19	7.5k	0603, 1/10W, 1%	Rohm	MCR03EZPFX7501
13	1	L1	0.82uH	0.82uH, DCR=4.3mohm	TDK	SPM6550T-R82M
14	1	R1	2k	0603, 1/10W, 1%	Rohm	MCR03EZPFX2001
15	1	R2	4.02k	0603, 1/10W, 1%	Rohm	MCR03EZPFX4021
16	1	R9	66.5k	0603, 1/10W, 1%	Rohm	MCR03EZPFX6652
17	1	R4	130	0603, 1/10W, 1%	Rohm	MCR03EZPFX1300
18	1	R6	20	0603, 1/10W, 1%	Rohm	CRCW060320R0FKEA
19	11	R8 R10 R11 R14 R25 R35 R36 R37 R39 R40 R41	0 ohm	0603, 1/10W	Rohm	CRCW06030000Z0EA
20	1	R18	49.9k	0603, 1/10W, 1%	Rohm	MCR03EZPFX4992
21	2	R22 R26	0 ohm	1206, 1/4 W	Panasonic	ERJ-8GEY0R00V
22	2	R23 R31	4.99k	0603, 1/10W, 1%	Rohm	MCR03EZPFX4991
23	1	C80	10uF	0603, 10V, X5R, 20%	Murata	GRM188R61A106ME69D
24	1	U1	IR38060	IR38060 5mm X 6mm	International Rectifier	IR38060

•The electrolytic input capacitor used on this demo board is to eliminate the impact of the parasitic inductance of a long input power cable. It may not be necessarily needed in real applications.

TYPICAL OPERATING WAVEFORMS

$P_{Vin}=12.0V$, $V_{out}=1.2V$, $I_{out}=0A-6A$, $F_s=600kHz$, Room Temperature, no airflow

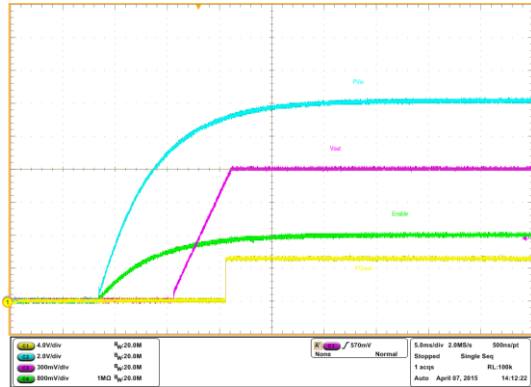

Fig. 2: P_{Vin} Start up at 6A Load
Ch₁: P_{Good} , Ch₂: P_{Vin} , Ch₃: V_{out} , Ch₄:Enable

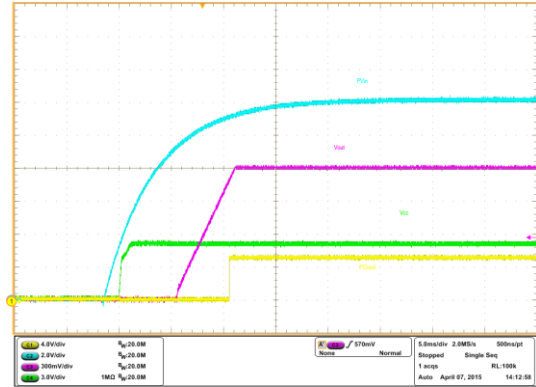

Fig. 3: P_{Vin} Start up at 6A Load
Ch₁: P_{Good} , Ch₂: P_{Vin} , Ch₃: V_{out} , Ch₄: V_{cc}

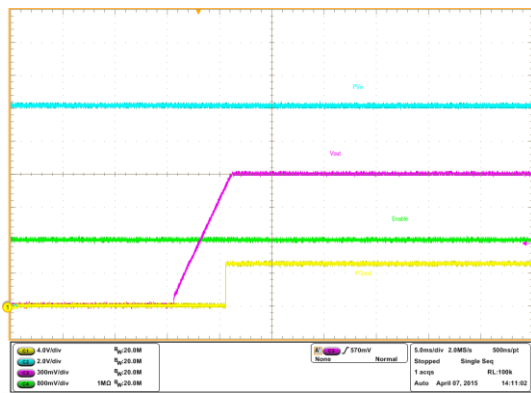

Fig. 4: Operation 80, Turn ON without margining, 6A load
Ch₁: P_{Good} , Ch₂: P_{Vin} , Ch₃: V_{out} , Ch₄:Enable

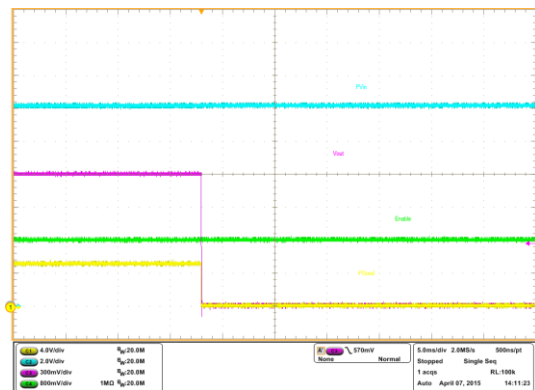

Fig. 5: Operation 00, Immediate OFF, 6A load
Ch₁: P_{Good} , Ch₂: P_{Vin} , Ch₃: V_{out} , Ch₄:Enable

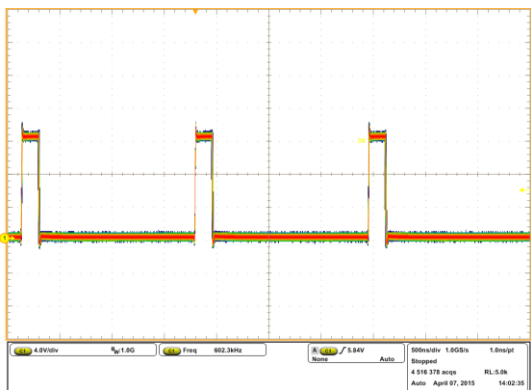

Fig. 6: Inductor node at 6A load
Ch₁:SW node

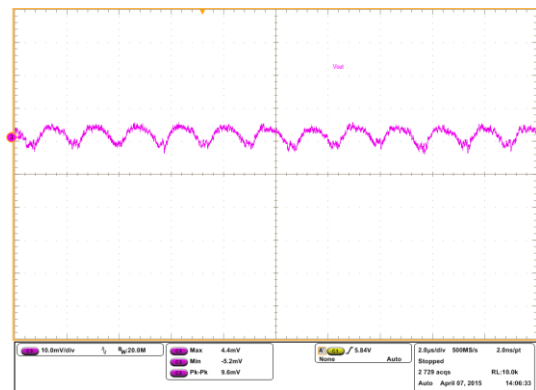

Fig. 7: Output voltage ripple at 6A load
Ch₃: V_{out}

TYPICAL OPERATING WAVEFORMS
 PVin=12.0V, Vout=1.2V, Iout=0A-6A, Fs=600kHz, Room Temperature, no airflow

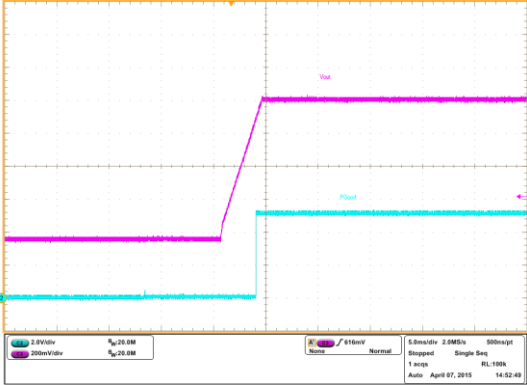

Fig. 8: 0.4V Prebias voltage startup at 0A load
 Ch₃:V_{out}, Ch₂:P_{Good}

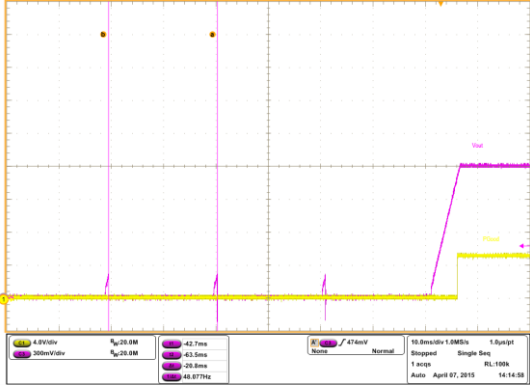

Fig. 9: Short-circuit recovery (Hiccup) at 6A load
 Ch₃:V_{out}, Ch₁:P_{Good}

TYPICAL OPERATING WAVEFORMS

PVin=12.0V, Vout=1.2V, Iout=0A-6A, Fs=600kHz, Room Temperature, no airflow

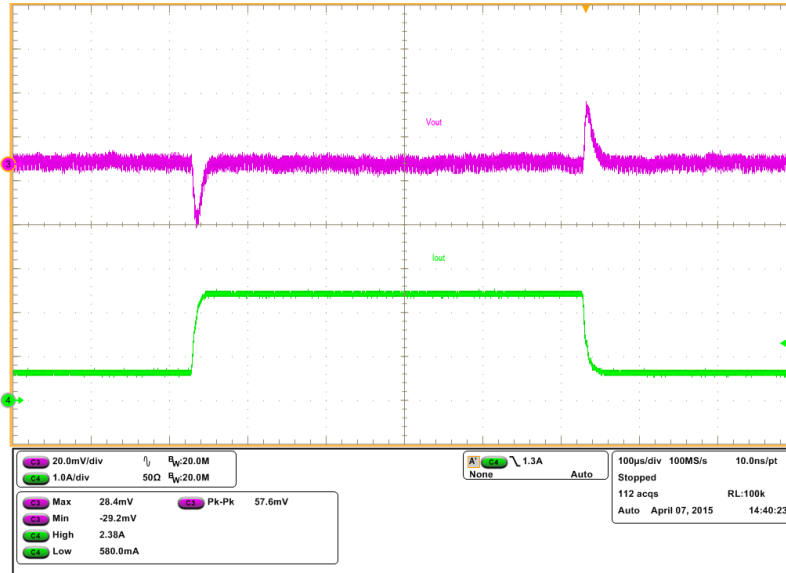

Fig. 10: Transient response, current step from 0.6A to 2.4A
 Ch₃:V_{out}, Ch₄:I_{out}

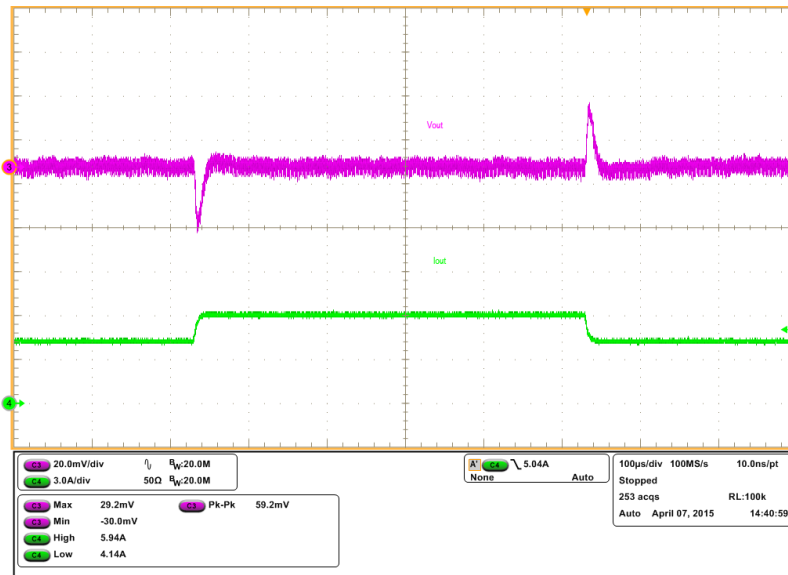

Fig. 11: Transient response, current step from 4.2A to 6A
 Ch₃:V_{out}, Ch₄:I_{out}

TYPICAL OPERATING WAVEFORMS

PVin=12.0V, Vout=1.2V, Iout=0A-6A, Fs=600kHz, Room Temperature, no airflow

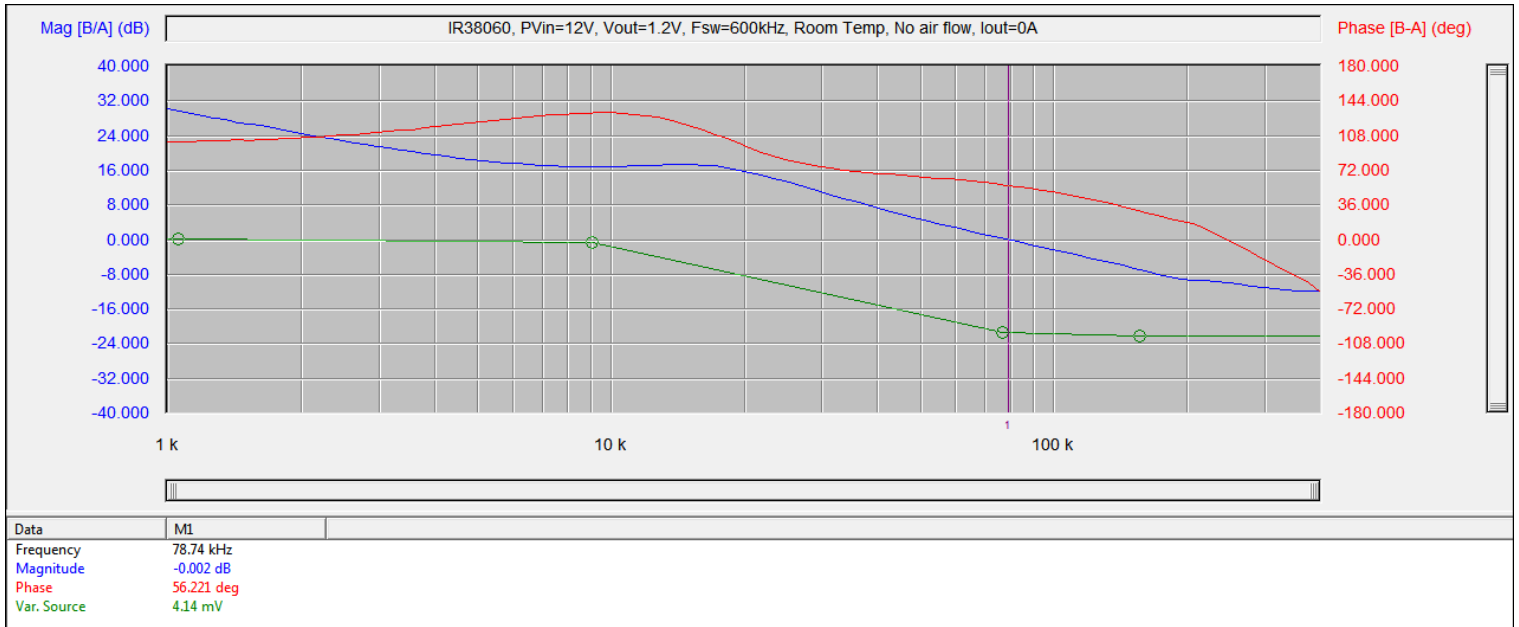

Fig. 12: Bode Plot at 0A load
Bandwidth = 78.7kHz, Phase Margin = 56.21 Degree

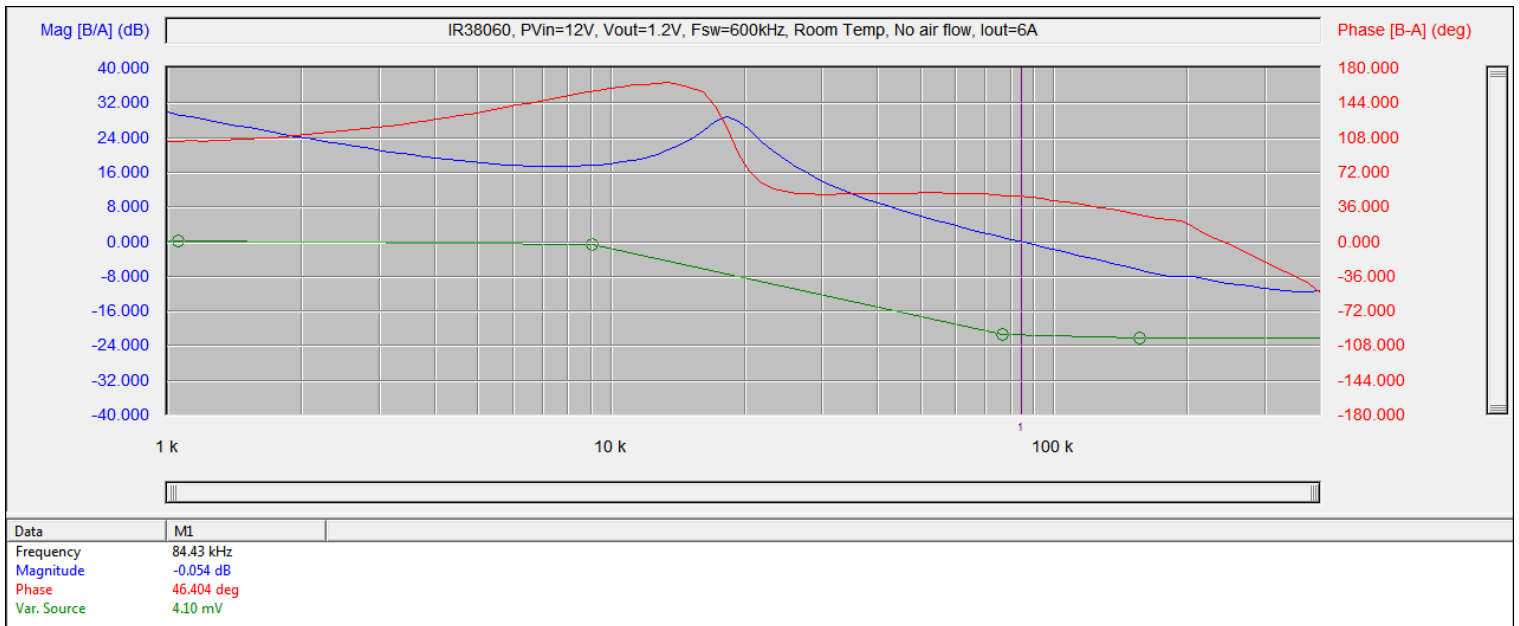

Fig. 13: Bode Plot at 6A load
Bandwidth = 84.4kHz, Phase Margin = 46.6 Degree

TYPICAL OPERATING WAVEFORMS

$P_{Vin}=12.0V$, $V_{out}=1.2V$, $I_{out}=0A-6A$, $F_s=600kHz$, Room Temperature, no airflow

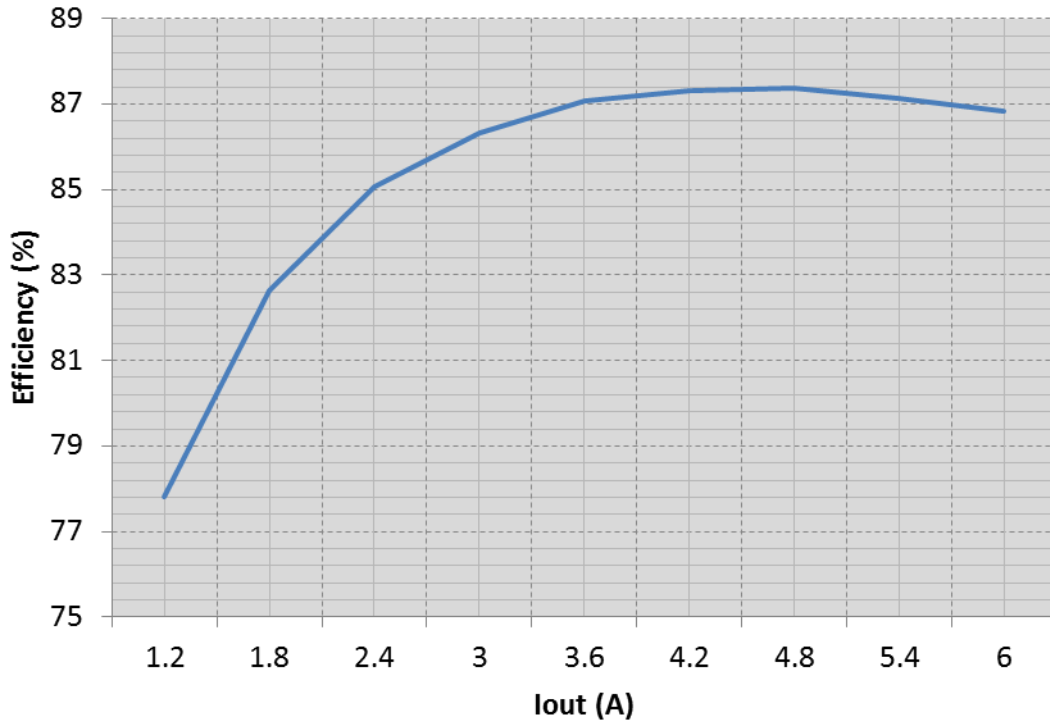

Fig14: Efficiency versus load current

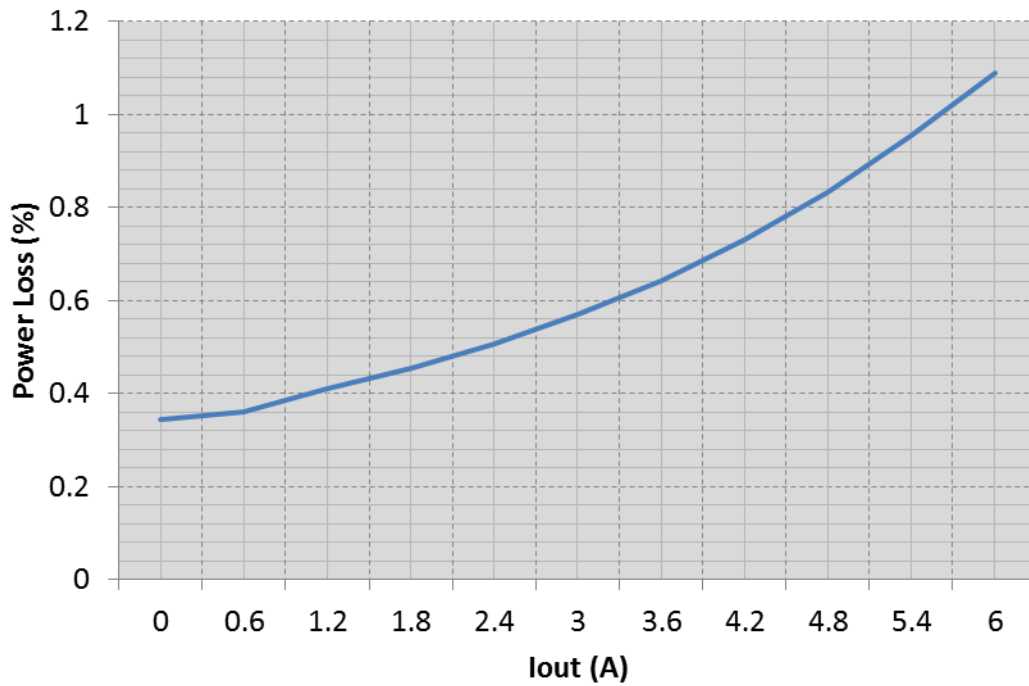

Fig.15: Power loss versus load current

TYPICAL OPERATING WAVEFORMS

PVin=12.0V, Vout=1.2V, Iout=0A-6A, Fs=600kHz, Room Temperature, no airflow

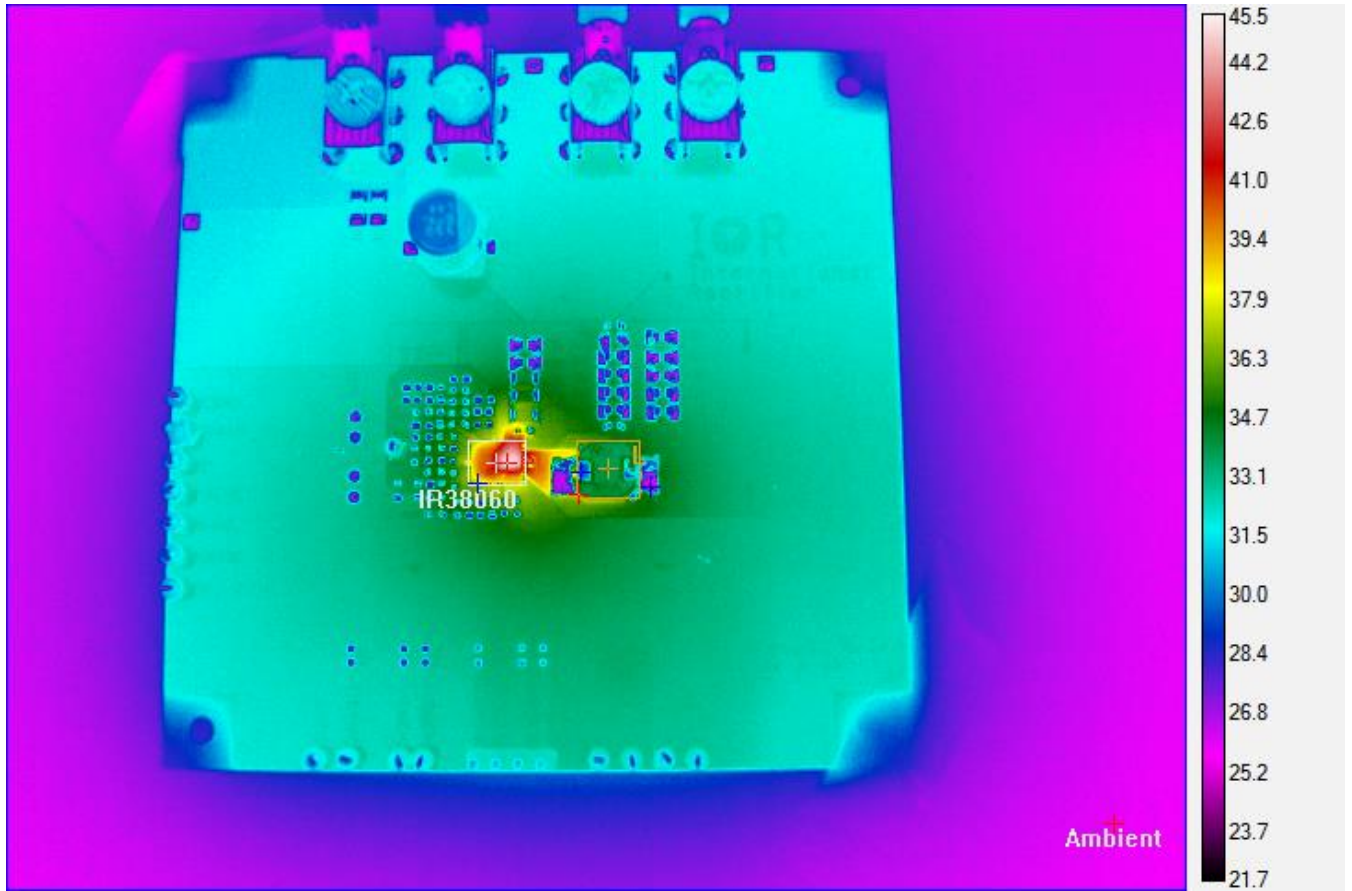

Fig. 16: Thermal Image of the board at 6A load
IR38060: 45.47°C, Inductor: 37.26°C, Ambient: 25.36°C

PMBus Command Summary

PVin=12.0V, Vout=1.2V, Iout=0A-6A, Fs=600kHz,

01	OPERATION	On	45	VOUT_UV_FAULT_RESPONSE	Ignore	64	TOFF_DELAY	0.0 ms
02	ON_OFF_CONFIG	0x1F	46	IOUT_OC_FAULT_LIMIT	9.000 A	65	TOFF_FALL	6.0 ms
10	WRITE_PROTECT	0x00	47	IOUT_OC_FAULT_RESPONSE	Immediate off, retry after 20ms	78	STATUS_BYTE	0x00
19	CAPABILITY	0xB0	4A	IOUT_OC_WARN_LIMIT	7.500 A	79	STATUS_WORD	0x0000
1B	SMBALERT_MASK		4F	OT_FAULT_LIMIT	145 °C	7A	STATUS_VOUT	0x00
	STATUS_VOUT	00	50	OT_FAULT_RESPONSE	Inhibit	7B	STATUS_IOUT	0x00
	STATUS_IOUT	00	51	OT_WARN_LIMIT	125 °C	7C	STATUS_INPUT	0x00
	STATUS_INPUT	00	55	VIN_OV_FAULT_LIMIT	24.000 V	7D	STATUS_TEMPERATURE	0x00
	STATUS_TEMPERATURE	00	56	VIN_OV_FAULT_RESPONSE	Ignore	7E	STATUS_CML	0x00
	STATUS_CML	00	58	VIN_UV_WARN_LIMIT	0.50 V	88	READ_VIN	12.156 V
21	VOUT_COMMAND	1.199 V	5E	POWER_GOOD_ON	1.074 V	8B	READ_VOUT	1.191 V
22	VOUT_TRIM	0.000 V	5F	POWER_GOOD_OFF	1.000 V	8C	READ_IOUT	0.000 A
24	VOUT_MAX	6.000 V	60	TON_DELAY	0.0 ms	8D	READ_TEMPERATURE_1	26 °C
25	VOUT_MARGIN_HIGH	1.262 V	61	TON_RISE	6.0 ms	96	READ_POUT	0.000 W
26	VOUT_MARGIN_LOW	1.141 V	62	TON_MAX_FAULT_LIMIT	0.000 ms	98	PMBUS_REVISION	0x22
27	VOUT_TRANSITION_RATE	0.125 mV/us	63	TON_MAX_FAULT_RESPONSE	Ignore	99	MFR_ID	IR
29	VOUT_SCALE_LOOP	1.000	64	TOFF_DELAY	0.0 ms	9A	MFR_MODEL	0x30
33	FREQUENCY_SWITCH	600 KHz	65	TOFF_FALL	6.0 ms	9B	MFR_REVISION	0x04
35	VIN_ON	1.000 V	78	STATUS_BYTE	0x00	AD	IC_DEVICE_ID	0x30
36	VIN_OFF	0.500 V	79	STATUS_WORD	0x0000	AE	IC_DEVICE_REV	0x04
39	IOUT_CAL_OFFSET	0.000 A	7A	STATUS_VOUT	0x00	D6	MFR_I2C_ADDRESS	0x10
40	VOUT_OV_FAULT_LIMIT	1.500 V	7B	STATUS_IOUT	0x00	D8	MFR_TPGDLY	0 ms
41	VOUT_OV_FAULT_RESPONSE	Shutdown	7C	STATUS_INPUT	0x00	D9	MFR_FCCM	Forced Cont. Conduction M...
42	VOUT_OV_WARN_LIMIT	1.379 V	7D	STATUS_TEMPERATURE	0x00	DB	MFR_VOUT_PEAK	1.191 V
43	VOUT_UV_WARN_LIMIT	1.020 V	7E	STATUS_CML	0x00	DC	MFR_IOUT_PEAK	0.0 A
44	VOUT_UV_FAULT_LIMIT	0.961 V	88	READ VIN	11.969 V	DD	MFR_TEMP_PEAK	26 °C

Fig. 17: PMBus Command Summary

Quick Start: PowIRCenter GUI
Connecting devices

Step 1

Start PowIRCenter & Connect USB Dongle

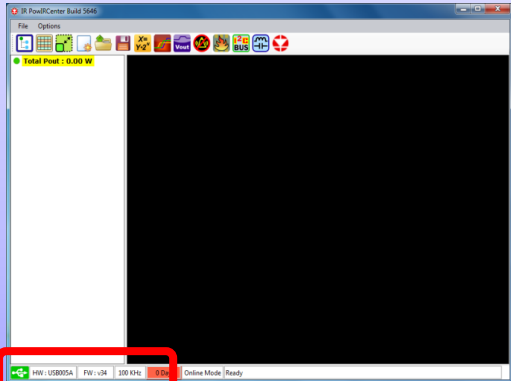

	HW : USB005A	FW : v34	100 KHz	USB Dongle connected
	HW : USBxxx	FW : v	100 KHz	USB Dongle NOT detected

Step 2

Detect attached demoboards



Press "Auto Populate Devices" button to detect boards connected to USB dongle

Quick Start: PowIRCenter GUI Navigation: Accessing Different Views

Step 3 Access different views

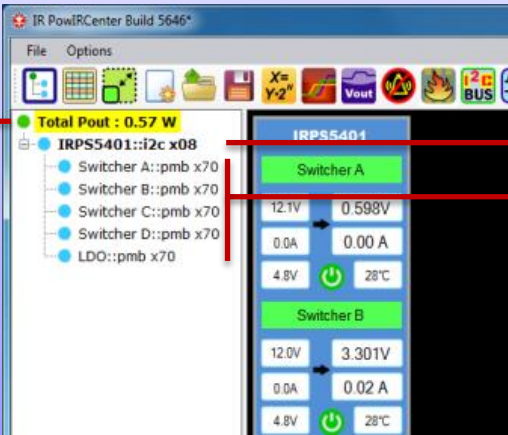

IRPS5401::i2c x08

Click **device name** to access save / load configuration files menu.

Switcher B::pmb x70

Click **channel** to access PMBus commands for selected channel

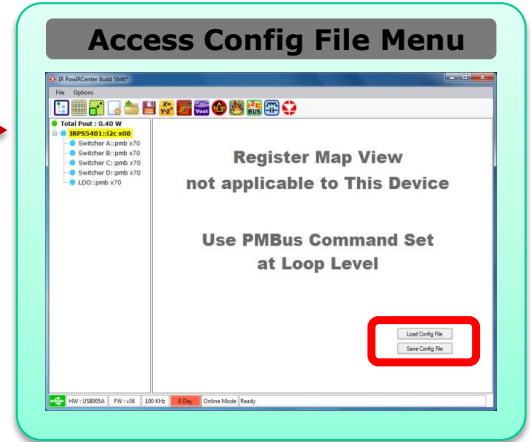

Total Pout : 0.57 W

Click **Total Pout** to return to the Board View

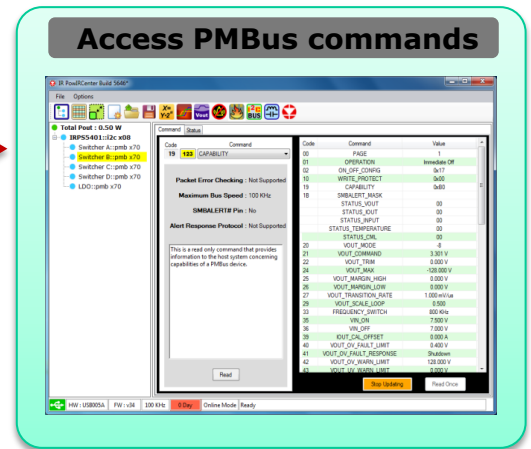
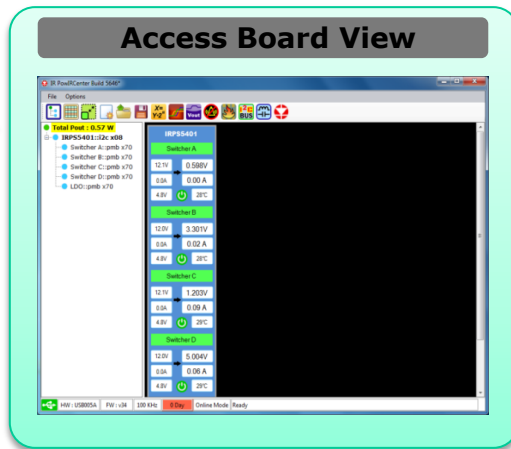

Quick Start: PowIRCenter GUI PMBus Commands

Select Command for Selected Channel

Select command from pull down List

or

Click the command in right panel.

PMBus Command Screen

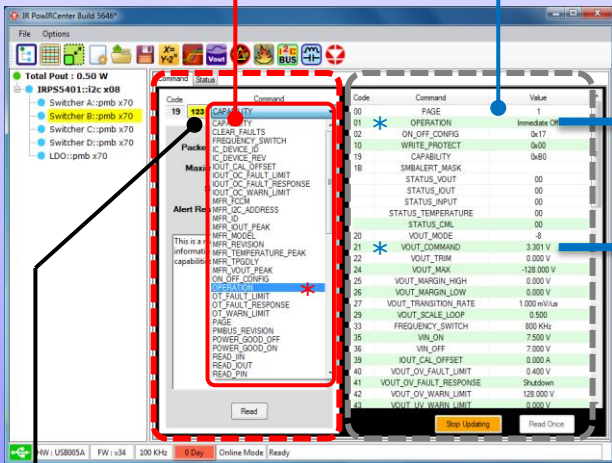

Enable / Disable Channel (Command: OPERATION)

1. Ensure the channel enable is set high on board.
2. Click "On" or "Immediate Off" to turn on or off the channel.
3. Click "Write" button to send the command.

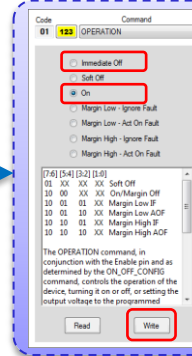

Change Vout (Command: VOUT_COMMAND)

1. Enter Vout voltage.
2. Press enter after entering value.
3. Click "Write" button to send the command.

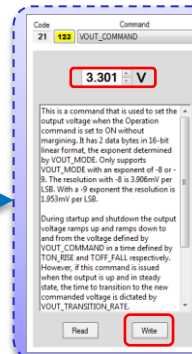

View Basic or All PMBus Commands

Click **A-Z** to sort the PMBus commands by name

Click **123** to sort PMBus commands by operation code