

1-A SIMPLE STEP-DOWN SWITCHING VOLTAGE REGULATORS

 Check for Samples: [TL2575HV-33-Q1](#), [TL2575HV-05-Q1](#)

FEATURES

- Fixed 3.3-V and 5-V Options With $\pm 5\%$ Regulation (Max) Over Line, Load, and Temperature Conditions
- Specified 1-A Output Current
- Wide Input Voltage Range...4.75 V to 60 V
- Require Only Four External Components (Fixed Versions) and Use Readily Available Standard Inductors
- 52-kHz (Typ) Fixed-Frequency Internal Oscillator
- TTL Shutdown Capability With 50- μ A (Typ) Standby Current
- High Efficiency...as High as 88% (Typ)
- Thermal Shutdown and Current-Limit Protection With Cycle-by-Cycle Current Limiting

APPLICATIONS

- Simple High-Efficiency Step-Down (Buck) Regulators
- Pre-Regulators for Linear Regulators
- On-Card Switching Regulators
- Positive-to-Negative Converters (Buck-Boost)

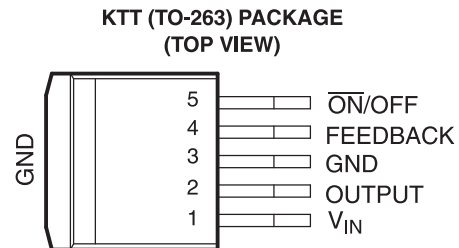

DESCRIPTION/ORDERING INFORMATION

The TL2575HV-33 and TL2575HV-05 greatly simplify the design of switching power supplies by conveniently providing all the active functions needed for a step-down (buck) switching regulator in an integrated circuit. Accepting a wide input voltage range of up to 60 V and available in fixed output voltages of 3.3 V or 5 V, the TL2575HV-33 and TL2575HV-05 have an integrated switch capable of delivering 1 A of load current, with excellent line and load regulation. The device also offers internal frequency compensation, a fixed-frequency oscillator, cycle-by-cycle current limiting, and thermal shutdown. In addition, a manual shutdown is available via an external ON/OFF pin.

The TL2575HV-33 and TL2575HV-05 represent superior alternatives to popular three-terminal linear regulators. Due to their high efficiency, the devices significantly reduce the size of the heat sink and, in many cases, no heat sink is required. Optimized for use with standard series of inductors available from several different manufacturers, the TL2575HV-33 and TL2575HV-05 greatly simplify the design of switch-mode power supplies by requiring a minimal addition of only four to six external components for operation.

The TL2575HV-33 and TL2575HV-05 are characterized for operation over the virtual junction temperature range of -40°C to 125°C .

ORDERING INFORMATION⁽¹⁾

T_J	V_O (NOM)	PACKAGE ⁽²⁾		ORDERABLE PART NUMBER	TOP-SIDE MARKING
-40°C to 125°C	3.3 V	TO-263 – KTT	Reel of 500	TL2575HV-33QKTTRQ1	2BHV-33Q
	5 V	TO-263 – KTT	Reel of 500	TL2575HV-05QKTTRQ1	2BHV-05Q

(1) For the most current package and ordering information, see the Package Option Addendum at the end of this document, or see the TI web site at www.ti.com.

(2) Package drawings, standard packing quantities, thermal data, symbolization, and PCB design guidelines are available at www.ti.com/sc/package.



Please be aware that an important notice concerning availability, standard warranty, and use in critical applications of Texas Instruments semiconductor products and disclaimers thereto appears at the end of this data sheet.

FUNCTIONAL BLOCK DIAGRAM

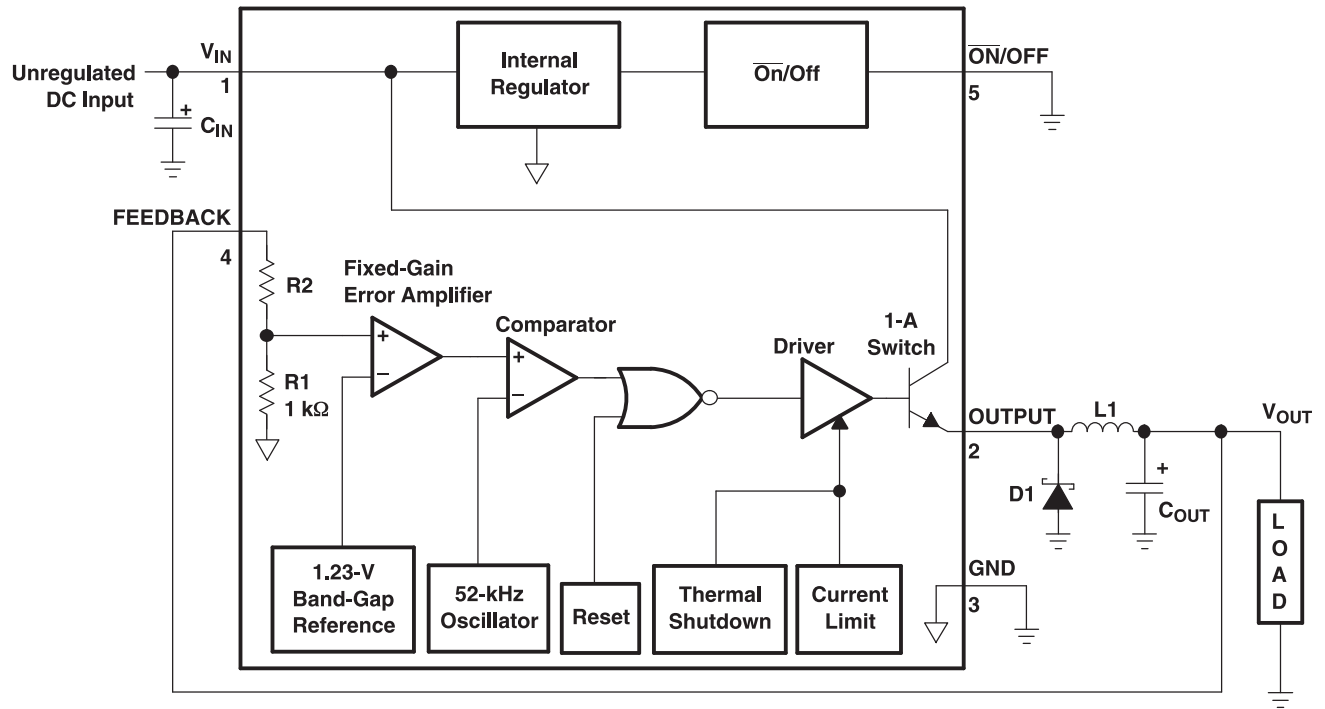

3.3 V: $R_2 = 1.7 \text{ k}\Omega$
 5 V: $R_2 = 3.1 \text{ k}\Omega$

ABSOLUTE MAXIMUM RATINGS⁽¹⁾

over operating free-air temperature range (unless otherwise noted)

		MIN	MAX	UNIT
V _{IN}	Supply voltage	TL2575HV	60	V
		TL2575	42	
$\overline{\text{ON}}$ /OFF input voltage range		-0.3	V _{IN}	V
Output voltage to GND (steady state)			-1	V
T _J	Maximum junction temperature		150	°C
T _{stg}	Storage temperature range	-65	150	°C

(1) Stresses beyond those listed under *absolute maximum ratings* may cause permanent damage to the device. These are stress ratings only, and functional operation of the device at these or any other conditions beyond those indicated under *recommended operating conditions* is not implied. Exposure to absolute-maximum-rated conditions for extended periods may affect device reliability.

PACKAGE THERMAL DATA⁽¹⁾

PACKAGE	BOARD	θ_{JA}	θ_{JC}	θ_{JP} ⁽²⁾
TO-263 (KTT)	High K, JESD 51-5	26.5°C/W	31.8°C/W	0.38°C/W

(1) Maximum power dissipation is a function of T_{J(max)}, θ_{JA} , and T_A. The maximum allowable power dissipation at any allowable ambient temperature is $P_D = (T_J(\text{max}) - T_A) / \theta_{JA}$. Operating at the absolute maximum T_J of 150°C can affect reliability.

(2) For packages with exposed thermal pads, such as QFN, PowerPAD™, or PowerFLEX™, θ_{JP} is defined as the thermal resistance between the die junction and the bottom of the exposed pad.

RECOMMENDED OPERATING CONDITIONS

		MIN	MAX	UNIT
V _{IN}	Supply voltage	4.75	60	V
T _J	Operating virtual junction temperature	-40	125	°C

ELECTRICAL CHARACTERISTICS

$I_{LOAD} = 200\text{ mA}$, $V_{IN} = 12\text{ V}$ for 3.3-V, 5-V (unless otherwise noted) (see [Figure 1](#))

PARAMETER		TEST CONDITIONS	T_J	TL2575HV			UNIT
				MIN	TYP	MAX	
V_{OUT}	Output voltage	TL2575HV-33 $V_{IN} = 12\text{ V}$, $I_{LOAD} = 0.2\text{ A}$ $4.75\text{ V} \leq V_{IN} \leq 60\text{ V}$, $0.2\text{ A} \leq I_{LOAD} \leq 1\text{ A}$	25°C	3.234	3.3	3.366	V
			25°C	3.168	3.3	3.450	
			Full range	3.135		3.482	
	TL2575HV-05 $V_{IN} = 12\text{ V}$, $I_{LOAD} = 0.2\text{ A}$ $8\text{ V} \leq V_{IN} \leq 60\text{ V}$, $0.2\text{ A} \leq I_{LOAD} \leq 1\text{ A}$	25°C	4.9	5	5.1		
		25°C	4.8	5	5.225		
		Full range	4.75		5.275		
η	Efficiency	TL2575HV-33 $V_{IN} = 12\text{ V}$, $I_{LOAD} = 1\text{ A}$	25°C	75			%
		TL2575HV-05 $V_{IN} = 12\text{ V}$, $I_{LOAD} = 1\text{ A}$		77			
f_o	Oscillator frequency ⁽¹⁾		25°C	47	52	58	kHz
			Full range	42		63	
V_{SAT}	Saturation voltage	$I_{OUT} = 1\text{ A}$ ⁽²⁾	25°C	0.9		1.2	V
			Full range			1.4	
	Maximum duty cycle ⁽³⁾		25°C	93	98		%
I_{CL}	Switch peak current ^{(1) (2)}		25°C	1.7	2.8	3.6	A
			Full range	1.3		4	
I_L	Output leakage current	$V_{IN} = 60$ ⁽⁴⁾ , Output = 0 V	25°C	2			mA
		$V_{IN} = 60$ ⁽⁴⁾ , Output = -1 V		7.5 30			
I_Q	Quiescent current ⁽⁴⁾		25°C	5 10		mA	
I_{STBY}	Standby quiescent current	OFF ($\overline{ON}/OFF = 5\text{ V}$)	25°C	50 200		μA	
V_{IH}	\overline{ON}/OFF high-level logic input voltage	OFF ($V_{OUT} = 0\text{ V}$)	25°C	2.2	1.4		V
			Full range	2.4			
V_{IL}	\overline{ON}/OFF low-level logic input voltage	ON ($V_{OUT} = \text{nominal voltage}$)	25°C	1.2 1		V	
			Full range				0.8
I_{IH}	\overline{ON}/OFF high-level input current	OFF ($\overline{ON}/OFF = 5\text{ V}$)	25°C	12 30		μA	
I_{IL}	\overline{ON}/OFF low-level input current	ON ($\overline{ON}/OFF = 0\text{ V}$)		0 10		μA	

- (1) In the event of an output short or an overload condition, self-protection features lower the oscillator frequency to ~18 kHz and the minimum duty cycle from 5% to ~2%. The resulting output voltage drops to ~40% of its nominal value, causing the average power dissipated by the IC to lower.
- (2) Output is not connected to diode, inductor, or capacitor. Output is sourcing current.
- (3) FEEDBACK is disconnected from output and connected to 0 V.
- (4) To force the output transistor off, FEEDBACK is disconnected from output and connected to 3.3 V and 5 V.

TEST CIRCUITS

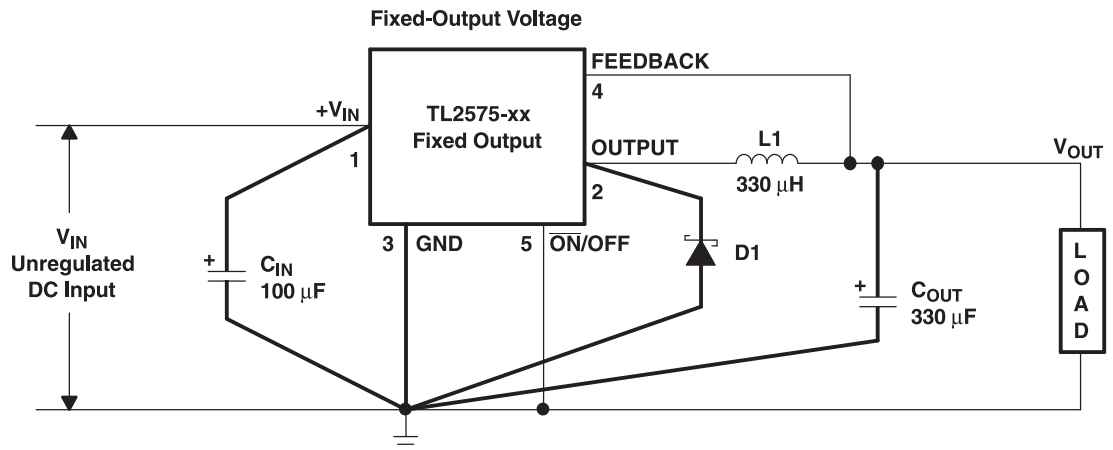

$C_{IN} = 100 \mu\text{F}$, Aluminum Electrolytic
 $C_{OUT} = 330 \mu\text{F}$, Aluminum Electrolytic
 $D1 = \text{Schottky}$
 $L1 = 330 \mu\text{H}$ (for 5-V V_{IN} with 3.3-V V_{OUT} , use 100 μH)

Figure 1. Test Circuits and Layout Guidelines

TYPICAL CHARACTERISTICS

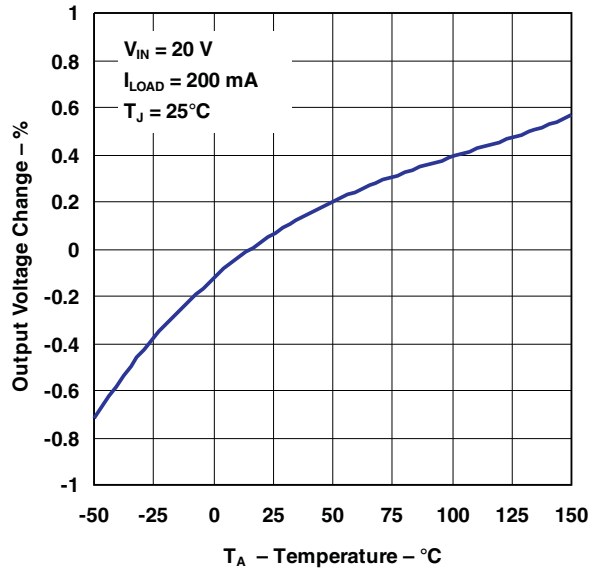

Figure 2. Normalized Output Voltage

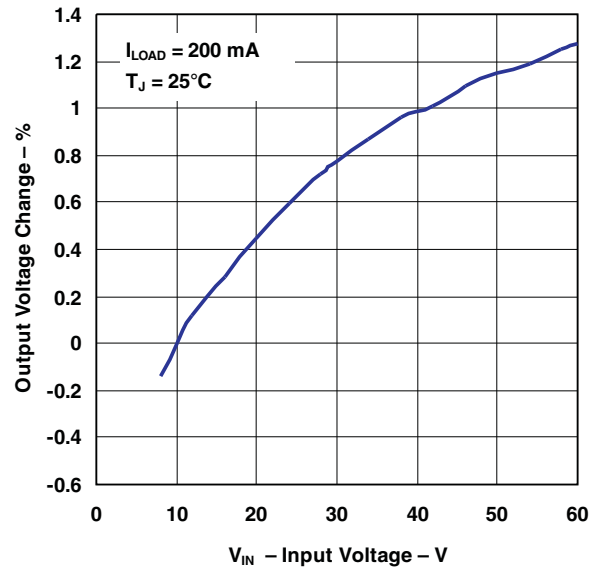

Figure 3. Line Regulation

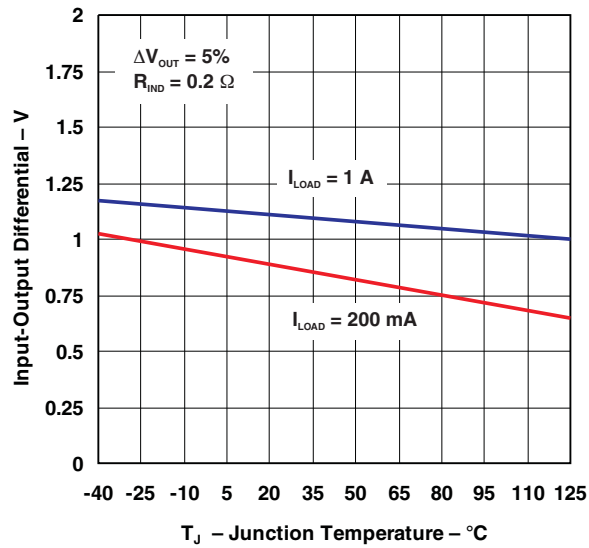

Figure 4. Dropout Voltage

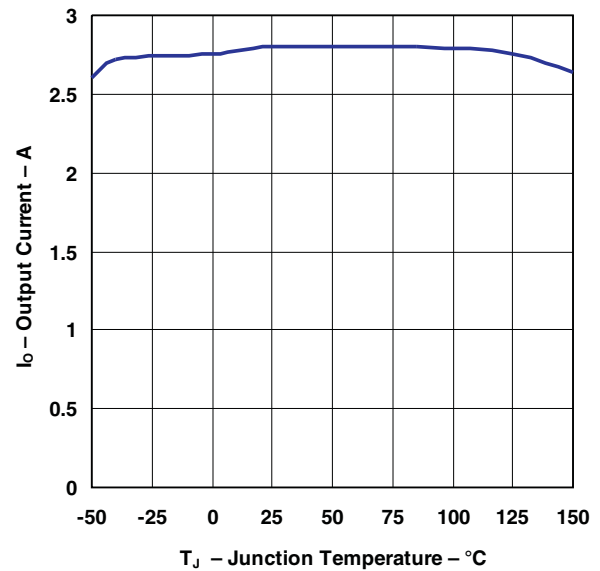

Figure 5. Current Limit

TYPICAL CHARACTERISTICS (continued)

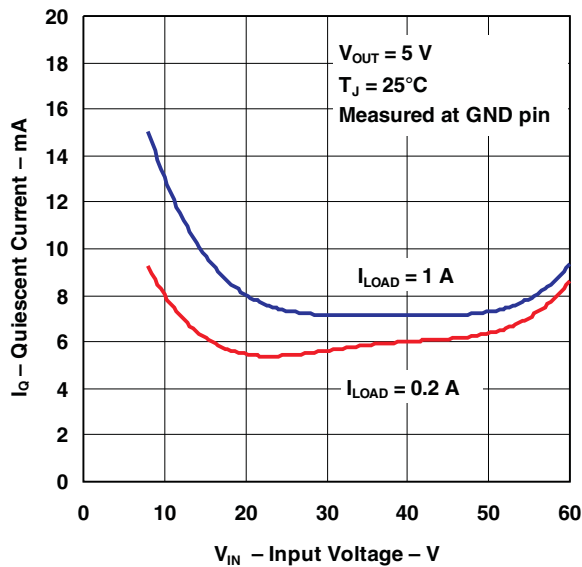

Figure 6. Quiescent Current

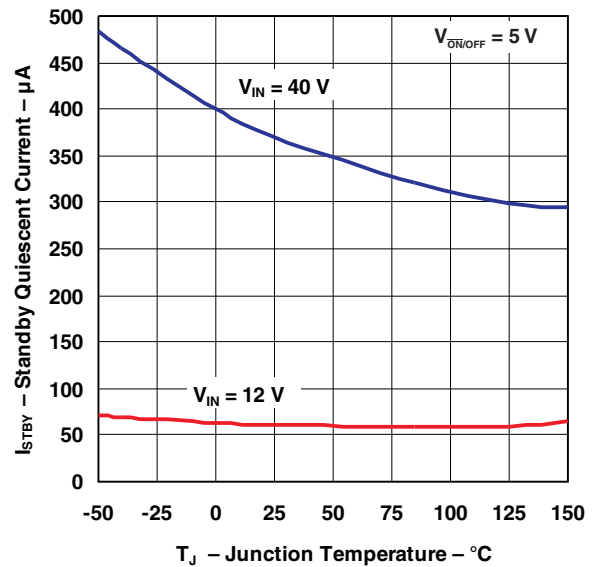

Figure 7. Standby Quiescent Current

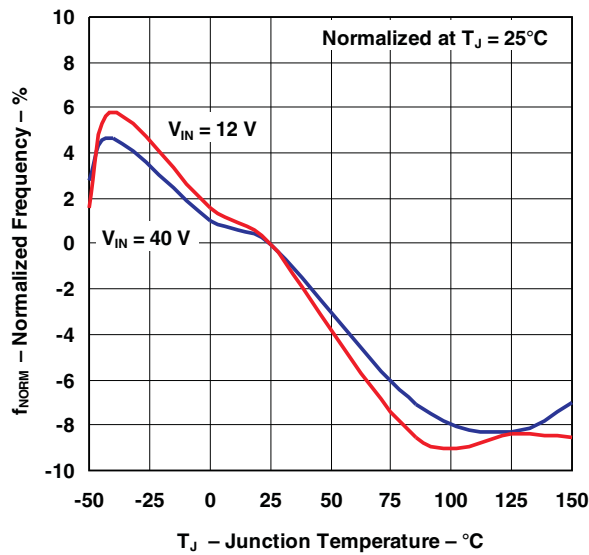

Figure 8. Oscillator Frequency

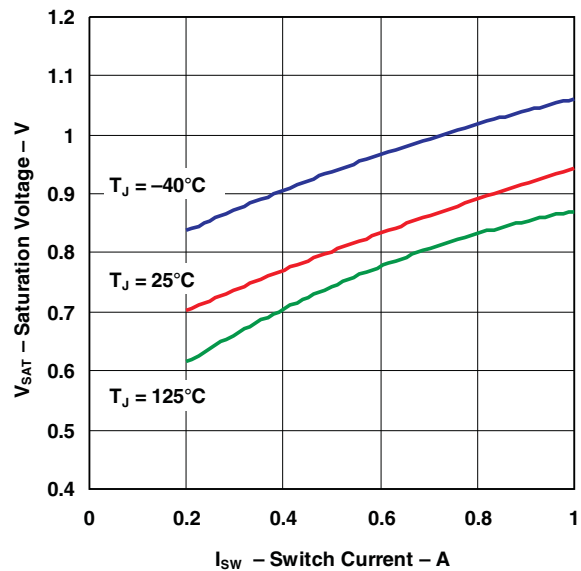
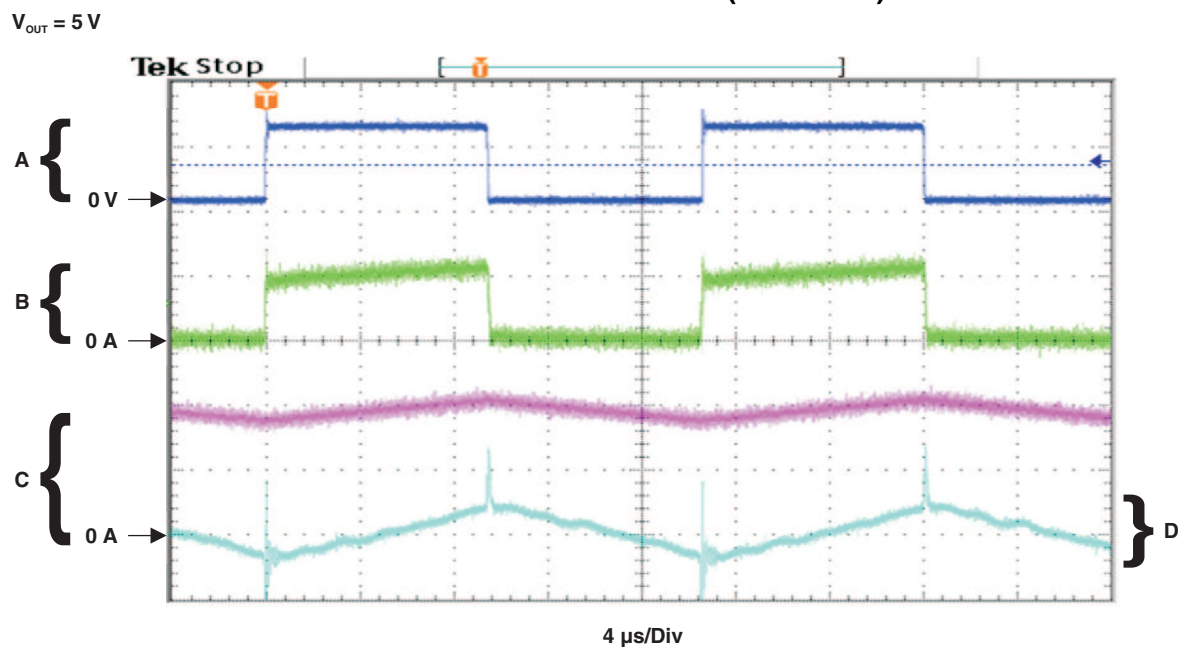

Figure 9. Switch Saturation Voltage

TYPICAL CHARACTERISTICS (continued)



D. Output ripple voltage, 20 mV/Div

Figure 10. Switching Waveforms

TYPICAL CHARACTERISTICS (continued)

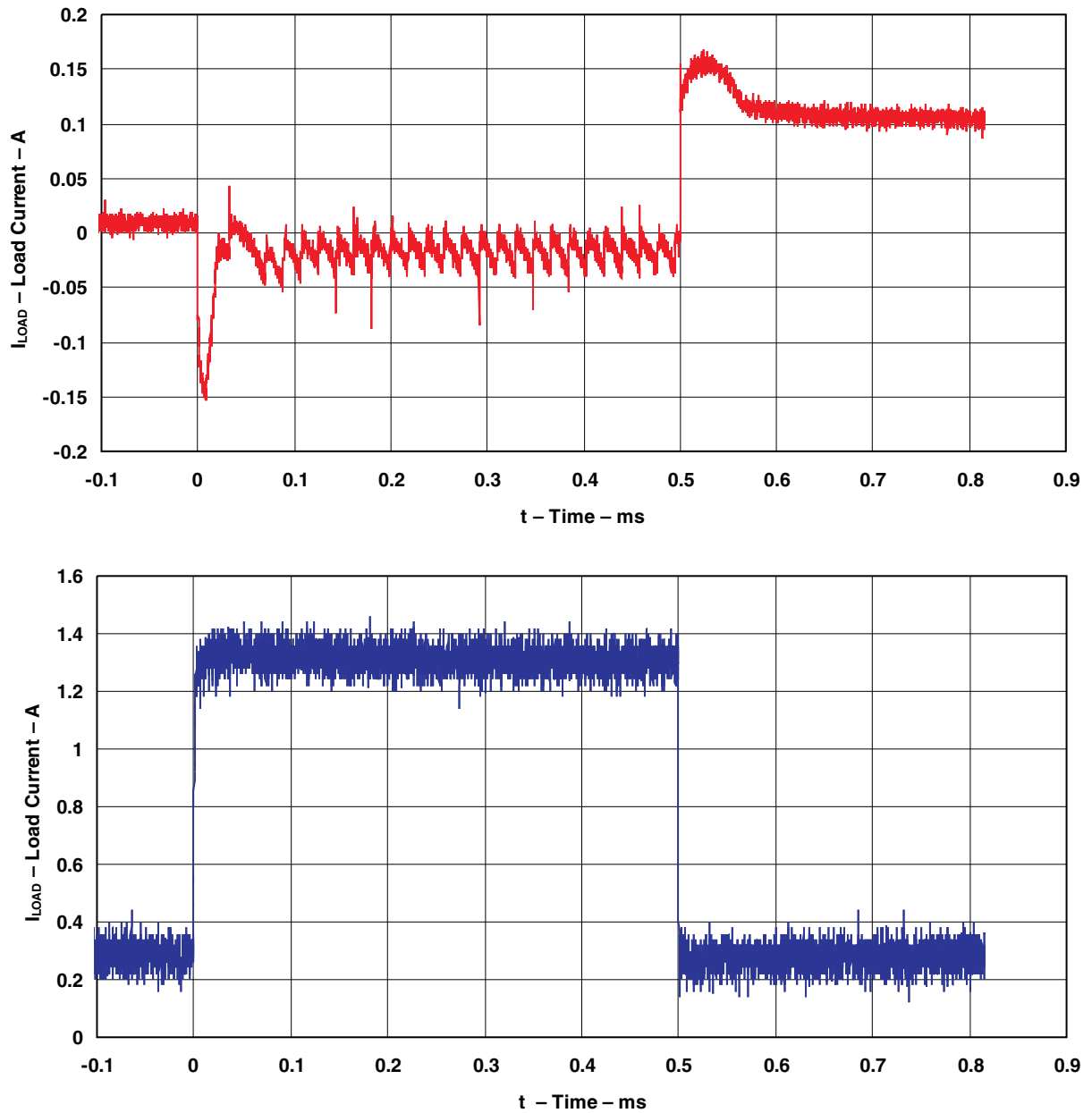

Figure 11. Load Transient Response

APPLICATION INFORMATION

Input Capacitor (C_{IN})

For stability concerns, an input bypass capacitor (electrolytic, $C_{IN} \geq 47 \mu\text{F}$) needs to be located as close as possible to the regulator. For operating temperatures below -25°C , C_{IN} may need to be larger in value. In addition, since most electrolytic capacitors have decreasing capacitances and increasing ESR as temperature drops, adding a ceramic or solid tantalum capacitor in parallel increases the stability in cold temperatures.

To extend the capacitor operating lifetime, the capacitor RMS ripple current rating should be:

$$I_{C,RMS} > 1.2(t_{on}/T)I_{LOAD}$$

where

$$t_{on}/T = V_{OUT}/V_{IN} \text{ \{buck regulator\} and}$$

$$t_{on}/T = |V_{OUT}|/(|V_{OUT}| + V_{IN}) \text{ \{buck-boost regulator\}}$$

Output Capacitor (C_{OUT})

For both loop stability and filtering of ripple voltage, an output capacitor also is required, again in close proximity to the regulator. For best performance, low-ESR aluminum electrolytics are recommended, although standard aluminum electrolytics may be adequate for some applications. Based on the following equation:

$$\text{Output ripple voltage} = (\text{ESR of } C_{OUT}) \times (\text{inductor ripple current})$$

Output ripple of 50 mV to 150 mV typically can be achieved with capacitor values of 220 μF to 680 μF . Larger C_{OUT} can reduce the ripple 20 mV to 50 mV peak to peak. To improve further on output ripple, paralleling of standard electrolytic capacitors may be used. Alternatively, higher-grade capacitors such as high frequency, low inductance, or low ESR can be used.

The following should be taken into account when selecting C_{OUT} :

- At cold temperatures, the ESR of the electrolytic capacitors can rise dramatically (typically 3x nominal value at -25°C). Because solid tantalum capacitors have significantly better ESR specifications at cold temperatures, they should be used at operating temperature lower than -25°C . As an alternative, tantalums also can be paralleled to aluminum electrolytics and should contribute 10% to 20% to the total capacitance.
- Low ESR for C_{OUT} is desirable for low output ripple. However, the ESR should be greater than 0.05 Ω to avoid the possibility of regulator instability. Hence, a sole tantalum capacitor used for C_{OUT} is most susceptible to this occurrence.
- The capacitor's ripple current rating of 52 kHz should be at least 50% higher than the peak-to-peak inductor ripple current.

Catch Diode

As with other external components, the catch diode should be placed close to the output to minimize unwanted noise. Schottky diodes have fast switching speeds and low forward voltage drops and, thus, offer the best performance, especially for switching regulators with low output voltages ($V_{OUT} < 5 \text{ V}$). If a high-efficiency, fast-recovery, or ultra-fast-recovery diode is used in place of a Schottky, it should have a soft recovery (versus abrupt turn-off characteristics) to avoid the chance of causing instability and EMI. Standard 50-/60-Hz diodes, such as the 1N4001 or 1N5400 series, are not suitable.

Inductor

Proper inductor selection is key to the performance-switching power-supply designs. One important factor to consider is whether the regulator is used in continuous mode (inductor current flows continuously and never drops to zero) or in discontinuous mode (inductor current goes to zero during the normal switching cycle). Each mode has distinctively different operating characteristics and, therefore, can affect the regulator performance and requirements. In many applications, the continuous mode is the preferred mode of operation, since it offers greater output power with lower peak currents, and also can result in lower output ripple voltage. The advantages of continuous mode of operation come at the expense of a larger inductor required to keep inductor current continuous, especially at low output currents and/or high input voltages.

The TL2575 and TL2575HV can operate in either continuous or discontinuous mode. With heavy load currents, the inductor current flows continuously and the regulator operates in continuous mode. Under light load, the inductor fully discharges and the regulator is forced into the discontinuous mode of operation. For light loads (approximately 200 mA or less), this discontinuous mode of operation is perfectly acceptable and may be desirable solely to keep the inductor value and size small. Any buck regulator eventually operates in discontinuous mode when the load current is light enough.

The type of inductor chosen can have advantages and disadvantages. If high performance/quality is a concern, then more-expensive toroid core inductors are the best choice, as the magnetic flux is contained completely within the core, resulting in less EMI and noise in nearby sensitive circuits. Inexpensive bobbin core inductors, however, generate more EMI as the open core does not confine the flux within the core. Multiple switching regulators located in proximity to each other are particularly susceptible to mutual coupling of magnetic fluxes from each other's open cores. In these situations, closed magnetic structures (such as a toroid, pot core, or E-core) are more appropriate.

Regardless of the type and value of inductor used, the inductor never should carry more than its rated current. Doing so may cause the inductor to saturate, in which case the inductance quickly drops, and the inductor looks like a low-value resistor (from the dc resistance of the windings). As a result, switching current rises dramatically (until limited by the current-by-current limiting feature of the TL2575 and TL2575HV) and can result in overheating of the inductor and the IC itself. Note that different types of inductors have different saturation characteristics.

Output Voltage Ripple and Transients

As with any switching power supply, the output of the TL2575 and TL2575HV have a sawtooth ripple voltage at the switching frequency. Typically about 1% of the output voltage, this ripple is due mainly to the inductor sawtooth ripple current and the ESR of the output capacitor (see note on C_{OUT}). Furthermore, the output also may contain small voltage spikes at the peaks of the sawtooth waveform. This is due to the fast switching of the output switch and the parasitic inductance of C_{OUT} . These voltage spikes can be minimized through the use of low-inductance capacitors.

There are several ways to reduce the output ripple voltage: a larger inductor, a larger C_{OUT} , or both. Another method is to use a small LC filter (20 μ H and 100 μ F) at the output. This filter can reduce the output ripple voltage by a factor of 10 (see [Figure 1](#)).

Feedback Connection

FEEDBACK must be wired to V_{OUT} . The resistor should be in close proximity to the regulator, and should be less than 100 k Ω to minimize noise pickup.

$\overline{ON/OFF}$ Input

$\overline{ON/OFF}$ should be grounded or be a low-level TTL voltage (typically <1.6 V) for normal operation. To shut down the TL2575 or TL2575HV and put it in standby mode, a high-level TTL or CMOS voltage should be supplied to this pin. $\overline{ON/OFF}$ should not be left open and safely can be pulled up to V_{IN} with or without a pullup resistor.

Grounding

The power and ground connections of the TL2575 and TL2575HV must be low impedance to help maintain output stability. For the 5-pin packages, both pin 3 and tab are ground, and either connection can be used as they are both part of the same lead frame. With the 16-pin package, all the ground pins (including signal and power grounds) should be soldered directly to wide PCB copper traces to ensure low-inductance connections and good thermal dissipation.

Layout Guidelines

With any switching regulator, circuit layout plays an important role in circuit performance. Wiring and parasitic inductances, as well as stray capacitances, are subjected to rapidly switching currents, which can result in unwanted voltage transients. To minimize inductance and ground loops, the length of the leads indicated by heavy lines should be minimized. Optimal results can be achieved by single-point grounding (see [Figure 1](#)) or by ground-plane construction.

BUCK REGULATOR DESIGN PROCEDURE

PROCEDURE (Fixed Output)	EXAMPLE (Fixed Output)
<p>Known: $V_{OUT} = 3.3\text{ V}, 5\text{ V}, 12\text{ V}, \text{ or } 15\text{ V}$ $V_{IN(Max)}$ = Maximum input voltage $I_{LOAD(Max)}$ = Maximum load current</p>	<p>Known: $V_{OUT} = 5\text{ V}$ $V_{IN(Max)} = 20\text{ V}$ $I_{LOAD(Max)} = 1\text{ A}$</p>
<p>1. Inductor Selection (L1)</p> <p>A. From Figure 12 through Figure 14, select the appropriate inductor code based on the intersection of $V_{IN(Max)}$ and $I_{LOAD(Max)}$.</p> <p>B. From Table 2, choose the appropriate inductor based on the inductor code. Parts from three well-known inductor manufacturers are given. The inductor chosen should be rated for operation at 52-kHz and have a current rating of at least $1.15 \times I_{LOAD(Max)}$ to allow for the ripple current. The actual peak current in L1 (in normal operation) can be calculated as follows: $I_{L1(pk)} = I_{LOAD(Max)} + (V_{IN} - V_{OUT}) \times t_{on}/2L1$ Where $t_{on} = V_{OUT}/V_{IN} \times (1/f_{osc})$</p>	<p>1. Inductor Selection (L1)</p> <p>A. From Figure 13 (TL2575-05), the intersection of 20-V line and 1-A line gives an inductor code of L330.</p> <p>B. L330 → L1 = 330 μH Choose from: 34042 (Schott) PE-52627 (Pulse Engineering) RL1952 (Renco)</p>
<p>2. Output Capacitor Selection (C_{OUT})</p> <p>A. The TL2575 control loop has a two-pole two-zero frequency response. The dominant pole-zero pair is established by C_{OUT} and L1. To meet stability requirements while maintaining an acceptable output ripple voltage ($V_{ripple} \neq 0.01 \times V_{OUT}$), the recommended range for a standard aluminum electrolytic C_{OUT} is between 100 μF and 470 μF.</p> <p>B. C_{OUT} should have a voltage rating of at least $1.5 \times V_{OUT}$. But if a low output ripple voltage is desired, choose capacitors with a higher-voltage ratings than the minimum required, due to their typically lower ESRs.</p>	<p>2. Output Capacitor Selection (C_{OUT})</p> <p>A. C_{OUT} = 100-μF to 470-μF, standard aluminum electrolytic</p> <p>B. Although a C_{OUT} rated at 8 V is sufficient for $V_{OUT} = 5\text{ V}$, a higher-voltage capacitor is chosen for its typically lower ESR (and hence lower output ripple voltage) → Capacitor voltage rating = 20 V.</p>
<p>3. Catch Diode Selection (D1) (see Table 1)</p> <p>A. In normal operation, the catch diode requires a current rating of at least $1.2 \times I_{LOAD(Max)}$. For the most robust design, D1 should be rated to handle a current equal to the TL2575 maximum switch peak current; this represents the worst-case scenario of a continuous short at V_{OUT}.</p> <p>B. The diode requires a reverse voltage rating of at least $1.25 \times V_{IN(Max)}$.</p>	<p>3. Catch Diode Selection (D1) (see Table 1)</p> <p>A. Pick a diode with 3-A rating.</p> <p>B. Pick 30-V rated Schottky diode (1N5821, MBR330, 31QD03, or SR303) or 100-V rated Fast Recovery diode (31DF1, MURD310, or HER302).</p>
<p>4. Input Capacitor (C_{IN})</p> <p>An aluminum electrolytic or tantalum capacitor is needed for input bypassing. Locate C_{IN} as close to the V_{IN} and GND pins as possible.</p>	<p>4. Input Capacitor (C_{IN})</p> <p>C_{IN} = 100 μF, 25 V, aluminum electrolytic</p>

Inductor Value Selection Guide for Continuous-Mode Operation

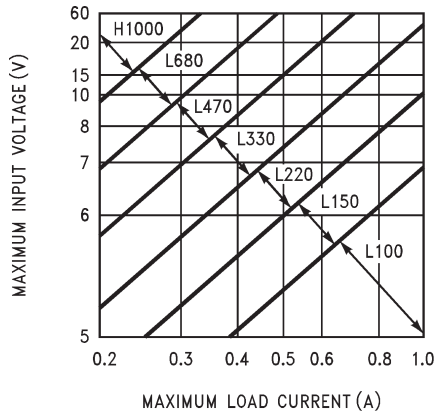

Figure 12. TL2575-33

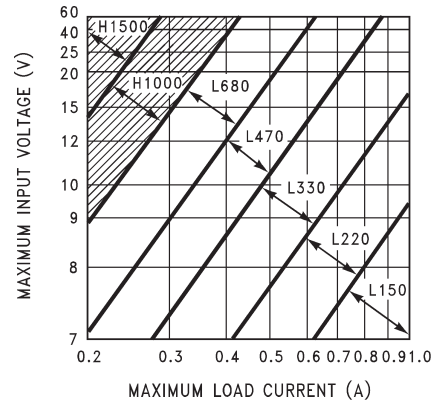

Figure 13. TL2575-50

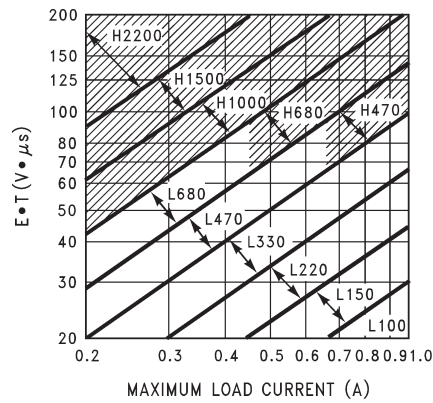

Figure 14. TL2575-ADJ

Table 1. Diode Selection Guide

V _R	SCHOTTKY		FAST RECOVERY	
	1A	3A	1A	3A
20 V	1N5817 MBR120P SR102	1N5820 MBR320 SR302	The following diodes are all rated to 100 V: 11DF1 MUR110 HER102	The following diodes are all rated to 100 V: 31DF1 MURD310 HER302
30 V	1N5818 MBR130P 11DQ03 SR103	1N5821 MBR330 31DQ03 SR303		
40 V	1N5819 MBR140P 11DQ04 SR104	1N5822 MBR340 31DQ04 SR304		
50 V	MBR150 11DQ05 SR105	MBR350 31DQ05 SR305		
60 V	MBR160 11DQ06 SR106	MBR360 31DQ06 SR306		

Table 2. Inductor Selection by Manufacturer's Part Number



INDUCTOR CODE	INDUCTOR VALUE (μ H)	SCHOTT CORPORATION ⁽¹⁾	PULSE ENGINEERING ⁽²⁾	RENCO ELECTRONICS ⁽³⁾
L100	100	67127000	PE-92108	RL2444
L150	150	67127010	PE-53113	RL1954
L220	220	67127020	PE-52626	RL1953
L330	330	67127030	PE-52627	RL1952
L470	470	67127040	PE-53114	RL1951
L680	680	67127050	PE-52629	RL1950
H150	150	67127060	PE-53115	RL2445
H220	220	67127070	PE-53116	RL2446
H330	330	67127080	PE-53117	RL2447
H470	470	67127090	PE-53118	RL1961
H680	680	67127100	PE-53119	RL1960
H1000	1000	67127110	PE-53120	RL1959
H1500	1500	67127120	PE-53121	RL1958
H2200	2200	67127130	PE-53122	RL2448

(1) Schott Corporation, (612) 475-1173, 1000 Parkers Lake Rd., Wayzata, MN 55391

(2) Pulse Engineering, (619) 674-8100, P.O. Box 12236, San Diego, CA 92112

(3) Renco Electronics Inc., (516) 586-5566, 60 Jeffry Blvd. East, Deer Park, NY 11729

PACKAGING INFORMATION

Orderable Device	Status (1)	Package Type	Package Drawing	Pins	Package Qty	Eco Plan (2)	Lead finish/ Ball material (6)	MSL Peak Temp (3)	Op Temp (°C)	Device Marking (4/5)	Samples
TL2575HV-05QKTTRQ1	ACTIVE	DDPAK/ TO-263	KTT	5	500	RoHS & Green	SN	Level-3-245C-168 HR	-40 to 125	2BHV-05Q	
TL2575HV-33QKTTRQ1	ACTIVE	DDPAK/ TO-263	KTT	5	500	RoHS & Green	SN	Level-3-245C-168 HR	-40 to 125	2BHV-33Q	

(1) The marketing status values are defined as follows:

ACTIVE: Product device recommended for new designs.

LIFEBUY: TI has announced that the device will be discontinued, and a lifetime-buy period is in effect.

NRND: Not recommended for new designs. Device is in production to support existing customers, but TI does not recommend using this part in a new design.

PREVIEW: Device has been announced but is not in production. Samples may or may not be available.

OBsolete: TI has discontinued the production of the device.

(2) **RoHS:** TI defines "RoHS" to mean semiconductor products that are compliant with the current EU RoHS requirements for all 10 RoHS substances, including the requirement that RoHS substance do not exceed 0.1% by weight in homogeneous materials. Where designed to be soldered at high temperatures, "RoHS" products are suitable for use in specified lead-free processes. TI may reference these types of products as "Pb-Free".

RoHS Exempt: TI defines "RoHS Exempt" to mean products that contain lead but are compliant with EU RoHS pursuant to a specific EU RoHS exemption.

Green: TI defines "Green" to mean the content of Chlorine (Cl) and Bromine (Br) based flame retardants meet JS709B low halogen requirements of <=1000ppm threshold. Antimony trioxide based flame retardants must also meet the <=1000ppm threshold requirement.

(3) MSL, Peak Temp. - The Moisture Sensitivity Level rating according to the JEDEC industry standard classifications, and peak solder temperature.

(4) There may be additional marking, which relates to the logo, the lot trace code information, or the environmental category on the device.

(5) Multiple Device Markings will be inside parentheses. Only one Device Marking contained in parentheses and separated by a "~" will appear on a device. If a line is indented then it is a continuation of the previous line and the two combined represent the entire Device Marking for that device.

(6) Lead finish/Ball material - Orderable Devices may have multiple material finish options. Finish options are separated by a vertical ruled line. Lead finish/Ball material values may wrap to two lines if the finish value exceeds the maximum column width.

Important Information and Disclaimer:The information provided on this page represents TI's knowledge and belief as of the date that it is provided. TI bases its knowledge and belief on information provided by third parties, and makes no representation or warranty as to the accuracy of such information. Efforts are underway to better integrate information from third parties. TI has taken and continues to take reasonable steps to provide representative and accurate information but may not have conducted destructive testing or chemical analysis on incoming materials and chemicals. TI and TI suppliers consider certain information to be proprietary, and thus CAS numbers and other limited information may not be available for release.

In no event shall TI's liability arising out of such information exceed the total purchase price of the TI part(s) at issue in this document sold by TI to Customer on an annual basis.

OTHER QUALIFIED VERSIONS OF TL2575HV-05-Q1, TL2575HV-33-Q1 :

- Catalog: [TL2575HV-05](#), [TL2575HV-33](#)

NOTE: Qualified Version Definitions:

- Catalog - TI's standard catalog product

TAPE AND REEL INFORMATION

QUADRANT ASSIGNMENTS FOR PIN 1 ORIENTATION IN TAPE

*All dimensions are nominal

Device	Package Type	Package Drawing	Pins	SPQ	Reel Diameter (mm)	Reel Width W1 (mm)	A0 (mm)	B0 (mm)	K0 (mm)	P1 (mm)	W (mm)	Pin1 Quadrant
TL2575HV-05QKTTRQ1	DDPAK/ TO-263	KTT	5	500	330.0	24.4	10.6	15.8	4.9	16.0	24.0	Q2
TL2575HV-33QKTTRQ1	DDPAK/ TO-263	KTT	5	500	330.0	24.4	10.6	15.8	4.9	16.0	24.0	Q2

TAPE AND REEL BOX DIMENSIONS

*All dimensions are nominal

Device	Package Type	Package Drawing	Pins	SPQ	Length (mm)	Width (mm)	Height (mm)
TL2575HV-05QKTTRQ1	DDPAK/TO-263	KTT	5	500	340.0	340.0	38.0
TL2575HV-33QKTTRQ1	DDPAK/TO-263	KTT	5	500	340.0	340.0	38.0

KTT (R-PSFM-G5)

PLASTIC FLANGE-MOUNT PACKAGE

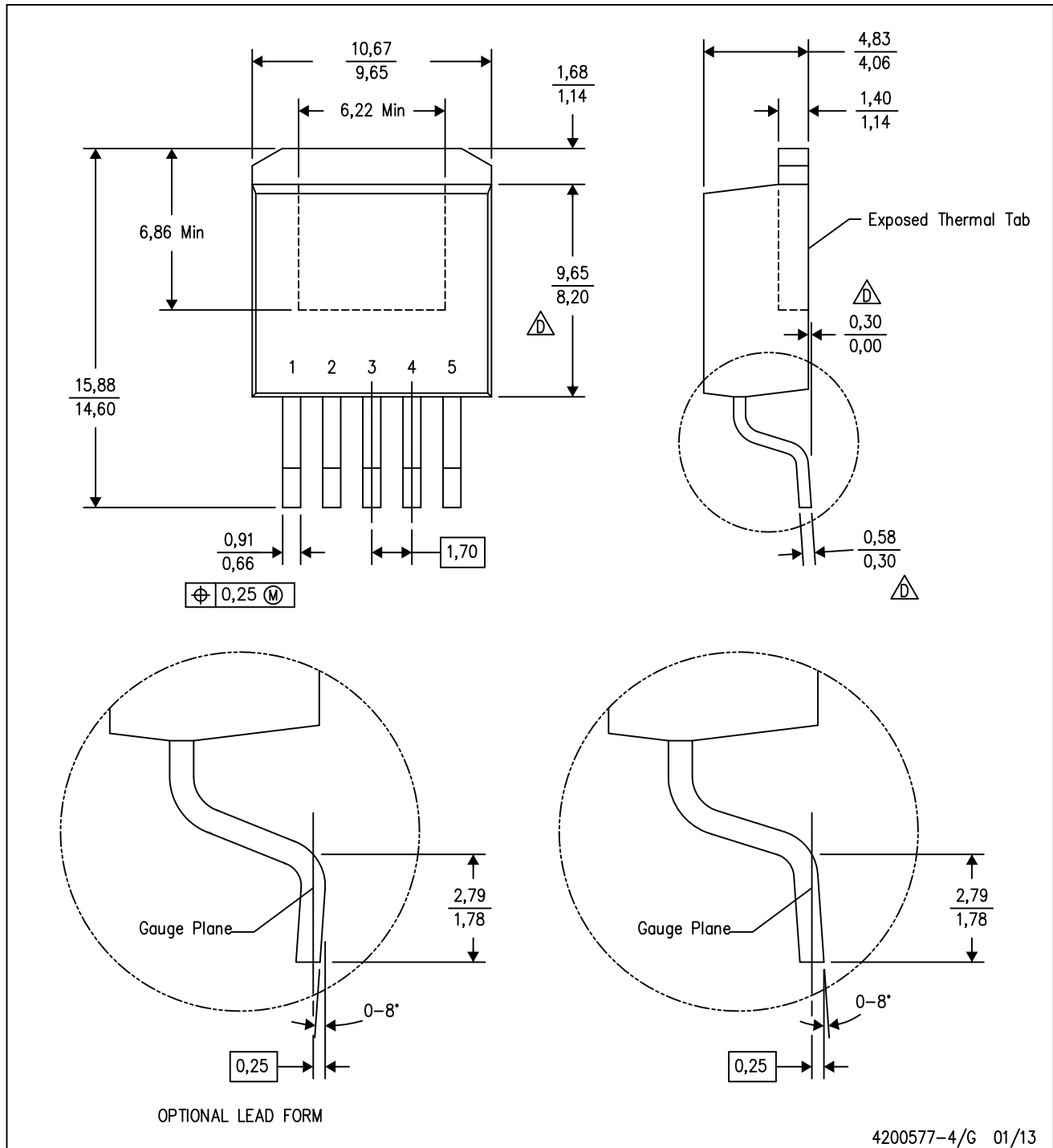

- NOTES:
- A. All linear dimensions are in millimeters.
 - B. This drawing is subject to change without notice.
 - C. Body dimensions do not include mold flash or protrusion. Mold flash or protrusion not to exceed 0.005 (0,13) per side.
- \triangle Falls within JEDEC TO-263 variation BA, except minimum lead thickness, maximum seating height, and minimum body length.

KTT (R-PSFM-G5)

PLASTIC FLANGE-MOUNT PACKAGE

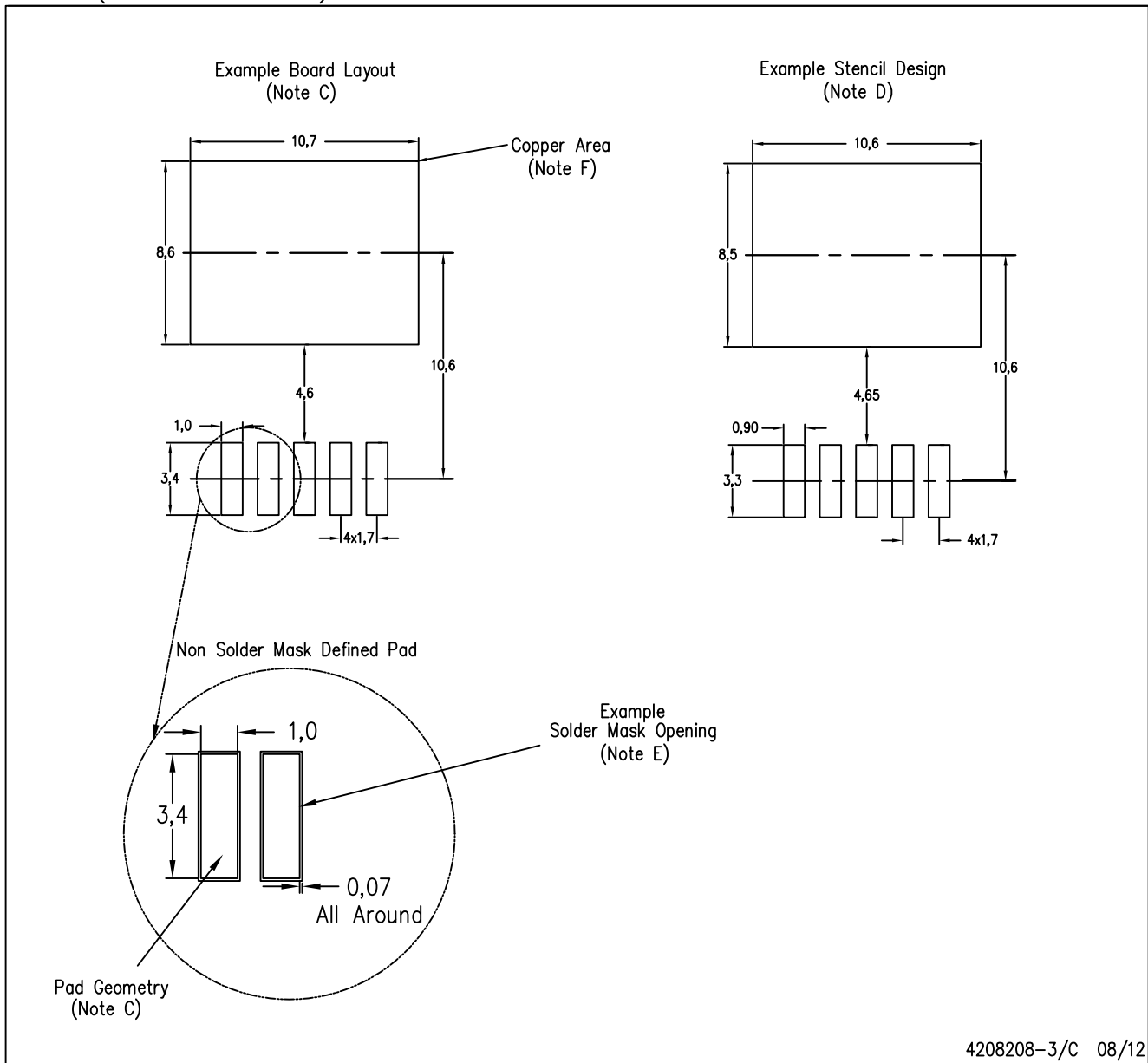

4208208-3/C 08/12

- NOTES:
- All linear dimensions are in millimeters.
 - This drawing is subject to change without notice.
 - Publication IPC-SM-782 is recommended for alternate designs.
 - Laser cutting apertures with trapezoidal walls and also rounding corners will offer better paste release. Customers should contact their board assembly site for stencil design recommendations. Refer to IPC-7525.
 - Customers should contact their board fabrication site for solder mask tolerances between and around signal pads.
 - This package is designed to be soldered to a thermal pad on the board. Refer to the Product Datasheet for specific thermal information, via requirements, and recommended thermal pad size. For thermal pad sizes larger than shown a solder mask defined pad is recommended in order to maintain the solderable pad geometry while increasing copper area.

IMPORTANT NOTICE AND DISCLAIMER

TI PROVIDES TECHNICAL AND RELIABILITY DATA (INCLUDING DATASHEETS), DESIGN RESOURCES (INCLUDING REFERENCE DESIGNS), APPLICATION OR OTHER DESIGN ADVICE, WEB TOOLS, SAFETY INFORMATION, AND OTHER RESOURCES "AS IS" AND WITH ALL FAULTS, AND DISCLAIMS ALL WARRANTIES, EXPRESS AND IMPLIED, INCLUDING WITHOUT LIMITATION ANY IMPLIED WARRANTIES OF MERCHANTABILITY, FITNESS FOR A PARTICULAR PURPOSE OR NON-INFRINGEMENT OF THIRD PARTY INTELLECTUAL PROPERTY RIGHTS.

These resources are intended for skilled developers designing with TI products. You are solely responsible for (1) selecting the appropriate TI products for your application, (2) designing, validating and testing your application, and (3) ensuring your application meets applicable standards, and any other safety, security, or other requirements. These resources are subject to change without notice. TI grants you permission to use these resources only for development of an application that uses the TI products described in the resource. Other reproduction and display of these resources is prohibited. No license is granted to any other TI intellectual property right or to any third party intellectual property right. TI disclaims responsibility for, and you will fully indemnify TI and its representatives against, any claims, damages, costs, losses, and liabilities arising out of your use of these resources.

TI's products are provided subject to TI's Terms of Sale (www.ti.com/legal/termsofsale.html) or other applicable terms available either on ti.com or provided in conjunction with such TI products. TI's provision of these resources does not expand or otherwise alter TI's applicable warranties or warranty disclaimers for TI products.

Mailing Address: Texas Instruments, Post Office Box 655303, Dallas, Texas 75265
Copyright © 2020, Texas Instruments Incorporated