

MI0603J601R-10

PHYSICAL DIMENSIONS:

| | | | |
|---|-------------|--------|---------|
| A | 1.60 [.063] | + 0.15 | [-.006] |
| B | 0.80 [.031] | + 0.15 | [-.006] |
| C | 0.80 [.031] | + 0.15 | [-.006] |
| D | 0.36 [.014] | + 0.15 | [-.006] |

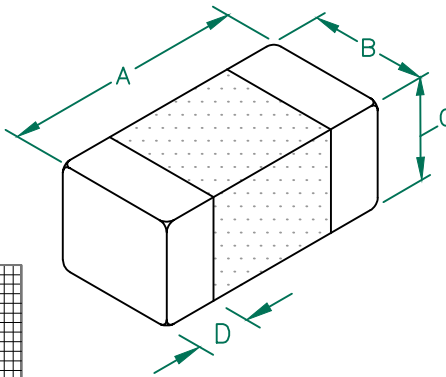

ELECTRICAL CHARACTERISTICS:

| | Z @ 100MHz (Ω) | DCR (Ω) | Rated Current |
|---------|-------------------|------------|------------------|
| Nominal | 600 | | |
| Minimum | 450 | | |
| Maximum | 750 | 0.20 | 1000 mA |

NOTES: UNLESS OTHERWISE SPECIFIED

1. TAPED AND REELED per CURRENT EIA SPECIFICATIONS 7" REELS, 4000 PCS/REEL.
2. TERMINATION FINISH IS 100% TIN.
3. COMPONENTS SHOULD BE ADEQUATELY PREHEATED BEFORE SOLDERING.
4. OPERATING TEMP. RANGE: -40°C~+125°C. (INCLUDING SELF-HEATING)
5. COSMETIC SPECIFICATION REFER TO WI-QA-124.

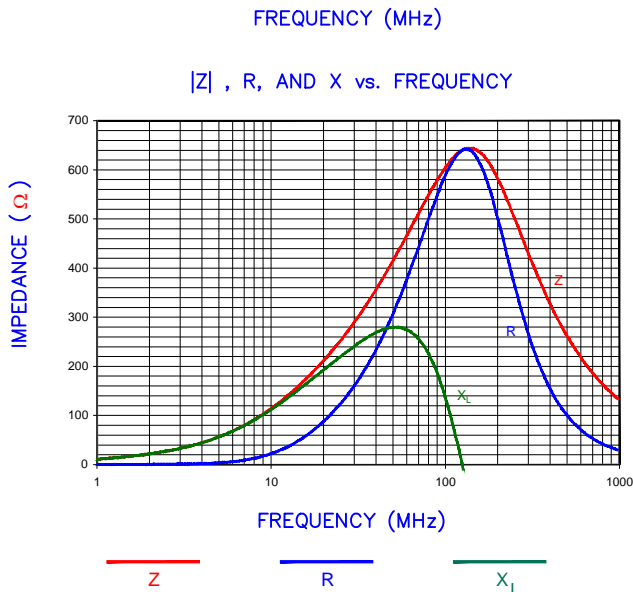
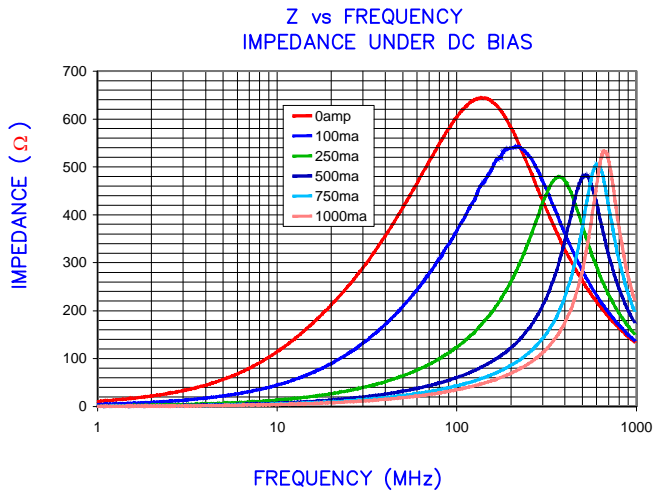

LAND PATTERNS FOR REFLOW SOLDERING

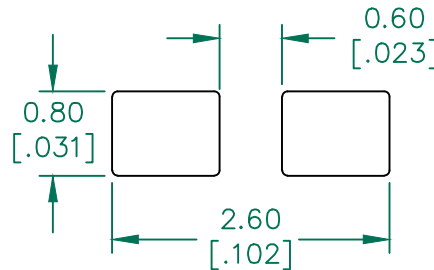

(For wave soldering, add 0.762 [.030] to this dimension)

RECOMMENDED SOLDERING CONDITIONS

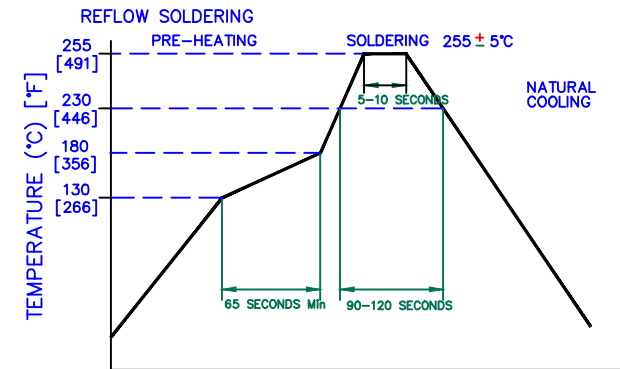

RoHS

| DIMENSIONS ARE IN mm [INCHES] | | | | This print is the property of Laird Tech. and is loaned in confidence subject to return upon request and with the understanding that no copies shall be made without the written consent of Laird Tech. All rights to design or invention are reserved. | | | |
|-------------------------------|--|----------|-----|---|------------------|---------------|---|
| C | ADD OPERATING TEMPERATURE UPDATE LAIRD LOGO AND REFLOW CURVE | 08/05/13 | QU | PROJECT/PART NUMBER: | MI0603J601R-10 | REV | C |
| B | UPDATE COMPANY LOGO | 07/24/08 | JRK | DATE: | 04/05/04 | SCALE: | - |
| A | ORIGINAL DRAFT | 04/05/04 | TMB | CAD # | MI0603J601R-10-C | TOOL # | - |
| REV | DESCRIPTION | DATE | INT | | | SHEET: 1 of 1 | |

